

Furniture collection



normann
C O P E N H A G E N

Normann Copenhagen is a Danish design company with the mission to create original and innovative products in a simple and contemporary design that withstands the test of time. Or in other words, to challenge conventional thinking and make the ordinary extraordinary through great design.

Established in 1999 by Jan Andersen and Poul Madsen, the Normann Copenhagen brand encompasses a wide and continuously growing collection of furniture, lighting, textiles and home accessories.

Content

- 06 How it all began
- 08 Made with care
- 10 Responsibility



Dining chairs

12

- 14 Form
- 28 Just
- 36 Hyg
- 46 My Chair
- 56 Knot
- 62 Herit
- 68 Ace
- 76 Studio
- 84 Timb



Sofas & lounge chairs

92

- 94 Ace lounge
- 100 My Chair lounge
- 108 Era
- 116 Hyg lounge
- 126 Sum
- 134 Swell
- 142 Pad
- 148 Rope



Poufs & stools

156

- 158 Tap
- 164 Circus
- 168 Silo



Tables

172

- 174 Union
- 184 Form café table
- 194 Slice
- 204 Journal



Coffee & side tables

210

- 212 Ding
- 216 Tablo
- 220 Stock
- 224 Turn
- 228 Lug
- 232 Solid
- 236 Pine
- 240 Stay
- 244 Grow
- 248 Block

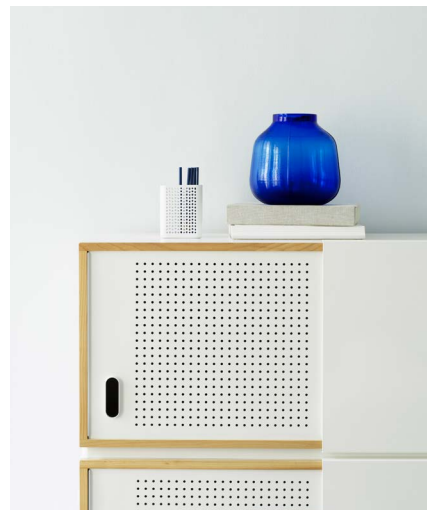

Storage

252

- 254 Jam
- 258 Kabino
- 264 Jalousi
- 270 Jet
- 274 Toj & Sko
- 278 One Step Up



Founders Jan Andersen & Poul Madsen

The story of Normann Copenhagen

The story of Normann Copenhagen began in a small provincial town in Denmark's Northeast Zealand where two young locals, Jan Andersen and Poul Madsen, crossed paths and found common ground in their love for design and their indomitable go-ahead spirit. They decided to join forces and create a shared business with interior design products as the focal point.

Since the inception, Jan and Poul have followed their heart's desire in terms of what and who they worked with, resulting in a vibrant variety of design products by renowned designers as well as up-and-coming talents. While working from the foundation of the Danish design heritage, they turn the chapter towards a modern lifestyle, pioneering a new heyday in Danish design and positioning Normann Copenhagen among the leading Danish design companies.

The collections are defined by clean lines with a twist and crafted with an emphasis on quality and endurance. Driven by creative curiosity, the brand draws on influences from the realms of art, fashion and culture, with an affinity for the bold and out of the ordinary. The products are sold in more than 80 countries throughout the world and have collected more than 80 design awards along the way. Still, Normann Copenhagen remains under the ownership and direction of its founders, uniting its global outlook with a familiar closeness and a design philosophy of making every space feel like home.

The making of



long-lasting design

A Normann Copenhagen product is shaped by curiosity, enthusiasm and by the whole-hearted creativity that forms the core of everything we do. We consider it our finest task to pass on our joy and excitement of design and infuse it into high-quality products crafted with attention to detail, materials, craftsmanship and durability. This is what we strive for: the making of long-lasting design.

In 2012, Normann Copenhagen established an in-house design studio with designers and engineers working closely together. This allows us to nurture every aspect of a design and shape the design processes all the way from initial idea to the final product. In addition to our in-house team, we collaborate with external designers from all over the world, who contribute to the conception of our wide-ranging collection.

When introducing a new design to the market, our skilled team of designers and engineers challenge existing ways

of production and utility of materials to create the best possible product, manufactured in the most responsible way. As a leading design manufacturer, we acknowledge our role in helping to care for our planet's resources, and we support the United Nations Development Goals for a more sustainable future.

We believe that design can be a part of improving quality of human life by making people happier. We build our expertise on a strong heritage of great craftsmanship and we use materials in new and innovative ways to make high-quality designs that will last for generations.

We all carry a responsibility for our ways of living and for the choices we make. Normann Copenhagen takes responsibility by making long-lasting products manufactured in a responsible and environmentally friendly way as well as taking social responsibility through a strong commitment to cultural and charitable projects.

Responsibility

As a leading design company producing accessories, lighting and furniture, we commit ourselves to help create a more sustainable world, in which we strive to constantly do better. To achieve our CSR mission, we have identified four areas where we believe we can have a positive impact on the environment and our surroundings.



Design and Materials

Normann Copenhagen utilizes more than 100 different types of materials, ranging from wood, steel and fabrics to glass, polymers and porcelain. Focusing on strength, durability and on reducing our environmental impact, our sourcing team works hard to select the best materials from the best-in-class suppliers.

Supply Chain

We produce our accessories, lamps and furniture in Europe and Asia. We believe it makes sense to produce as close to the market as possible: As we sell our products worldwide, we have decided to move closer to the markets with our production, sales staff and warehouses. At the same time, we can support local craftsmanship and its workforce.

Sponsorships

Since the company's establishment in 1999, it has been of great importance to us that we play a significant role in making a positive contribution to the society that surrounds us. We take great pride in taking social responsibility through our charity donations where we believe our contribution can make a significant difference. Likewise, we have supported numerous cultural initiatives within design, art, music, fashion, film and food, and our company is greatly inspired and influenced by these creative fields.

Our People

We treasure the people in our organization and see our employees as our biggest asset in order to succeed in our industry. Employing approximately 100 people worldwide, we are proud that 18 percent of our employees have been with us for more than 8 years and 35 percent for more than 5 years. We have achieved a diverse workforce counting over 26 different nationalities represented by 49% female and 51% male across the organization. We employ people because of their competencies and skills, irrespective of age, sex, race, religion or ethnicity.

If you are interested in reading more about our efforts on responsibility, we encourage you to visit our website normann-copenhagen.com



Dining chairs

Explore a varied and versatile range of minimalistic, elegant, harmonious and comfortable chairs, many of which can be tailored to match stylistic preferences. Flexibility is key, also when it comes to function. Swift swivel chairs and neat stackable designs are your trusted allies in the creation of hybrid, dynamic spaces that can adapt to changing needs.



Form chair full upholstery oak

Form

Uncompromising design and impeccable comfort

Form tells the story of a design company and a designer with the vision of creating the perfect chair. A tribute to form itself, the uncompromising design combines a strong design idiom with comfortable curves and an innovative industrial technique. The sleek mounting solution developed especially for the Form chair creates a natural integration between seat and base and makes it possible to mount different types of bases in the same openings. While retaining a homogenous and aesthetic design, the Form chair can be customized from more than 100.000 possible combinations of models, colors, textiles and bases, offering a wealth of opportunities for creative expression.



Form chair oak



Collection

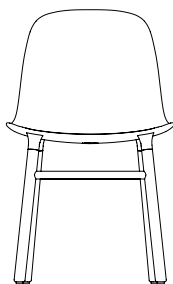

Form chair wood
H: 80 x L: 48 x D: 52 x
SH: 44 cm

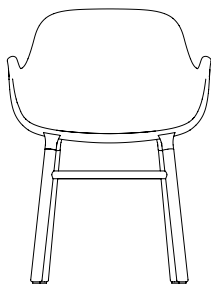

Form armchair wood
H: 80 x L: 56 x D: 52 x
SH: 44 x AR: 66,5 cm

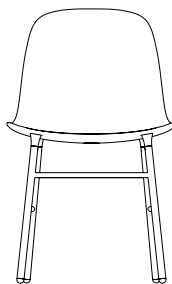

Form chair steel, chrome, brass
H: 80 x L: 48 x D: 52 x
SH: 44 cm

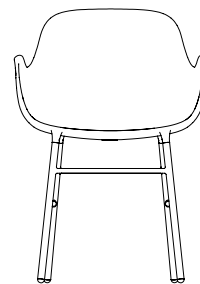

Form armchair steel, chrome, brass
H: 80 x L: 56 x D: 52 x
SH: 44 x AR: 66,5 cm

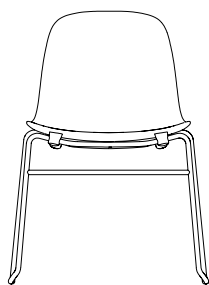

Form chair stacking steel, chrome
H: 80 x L: 58,5 x D: 52 x
SH: 44 cm

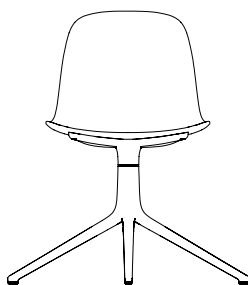

Form chair swivel 4L
H: 80 x L: 70,5 x D: 70,5 x
SH: 44 cm

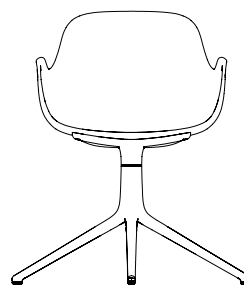

Form armchair swivel 4L
H: 80 x L: 70,5 x D: 70,5 x
SH: 44 x AR: 66,5 cm

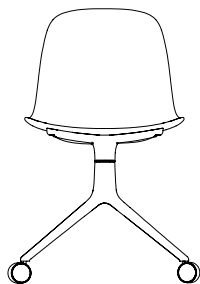

Form chair swivel 4W
H: 80 x L: 54 x D: 55,5 x
SH: 45 cm

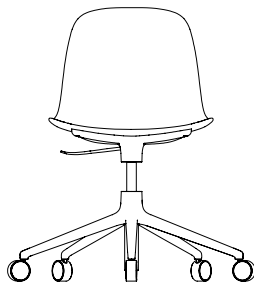

Form chair swivel 5W gaslift
H: 73/86 x L: 60 x D: 52 x
SH: 37/50 cm

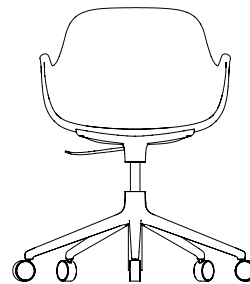

Form armchair swivel 5W gaslift
H: 73/86 x L: 72,5 x D: 72,5 x
SH: 37/50 x AR: 59/72 cm

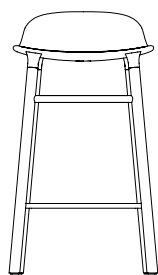

Form bar stool 65 cm wood
H: 77 x L: 43 x D: 42,5 x SH: 65 cm

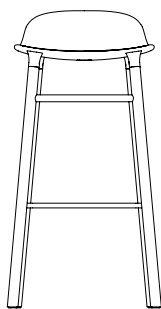

Form bar stool 75 cm wood
H: 87 x L: 45 x D: 45 x SH: 75 cm

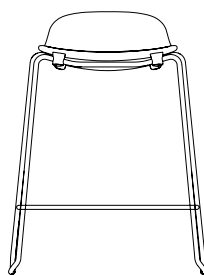

Form bar stool 65 cm stacking steel, chrome
H: 77,5 x L: 58,5 x D: 45 x SH: 65 cm

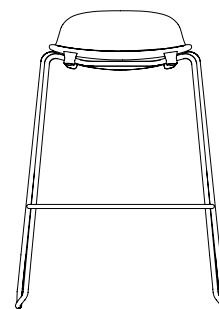

Form bar stool 75 cm stacking steel, chrome
H: 77,5 x L: 60,5 x D: 48,5 x SH: 75 cm

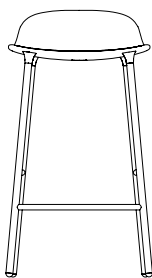

Form bar stool 65 cm steel, chrome, brass
H: 77 x L: 42,5 x D: 42,5 x SH: 65 cm

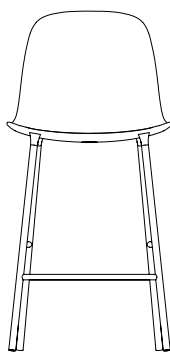

Form bar chair 65 cm steel
H: 100 x L: 48 x D: 52 x SH: 65 cm

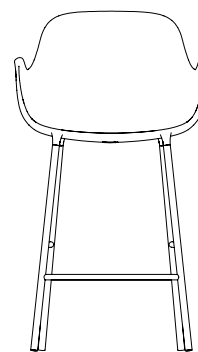

Form bar armchair 65 cm steel
H: 100 x L: 56 x D: 54,5 x SH: 65 x AR: 87 cm

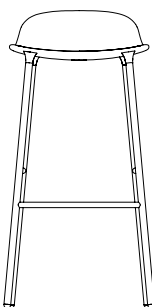

Form bar stool 75 cm steel, chrome, brass
H: 87 x L: 43 x D: 43 x SH: 75 cm

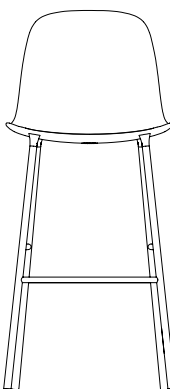

Form bar chair 75 cm steel
H: 110 x L: 49 x D: 54,5 x SH: 75 cm

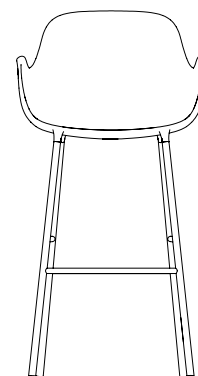

Form bar armchair 75 cm steel
H: 110 x L: 56 x D: 54,5 x SH: 75 x AR: 97 cm



Form armchair swivel 4L full upholstery aluminum



Above:

Form bar chair 65 cm steel,
Form chair steel,
Form bar chair 75 cm full upholstery steel



Above right:

Form bar armchair 65 cm steel with seat cushion,
Form bar chair 65 cm steel with seat cushion

Product facts

Description

Form is a contemporary chair series offering impeccable comfort and a strong design idiom. The unique connectors developed especially for the Form series create a smooth transition between the seat and frame, while making it possible to seamlessly adapt the chair to various kinds of leg types.

Designer / Year Of Design

Simon Legald / 2014

Material

Shell: Polypropylene / Polypropylene with upholstery
Legs: Powder coated steel / Chrome / Brass plated steel / Powder coated aluminum / Lacquered oak / Lacquered walnut / Painted and lacquered oak

Construction

Form is delivered assembled. The molded connectors match the legs in color, creating a seamless transition from legs to shell.

Stackability

The Form stacking chair and Form stacking barstool are stackable, up to 6 pcs. Compatible with our Chair Rack. Stackable up to 15 chairs on our single version Chair Rack and up to 30 on our double version Chair Rack.

Accessories

Comes with PE/POM/PP glides. Felt glides can be purchased separately. See Glides Overview.

Can be connected with Chair Link.

Form chair (wood, steel and stacking) is compatible with our Chair Suspension.

Form seat cushion for the Form chair and Form armchair can be purchased separately.

Test

Form chair wood, steel, chrome and brass

EN 1022:2005 and EN 16139:2013. Level 2

Form armchair wood, steel, chrome and brass

EN 1022:2005 and EN 16139:2013. Level 2

ANSI/BIFMA X5.4-2012

Form barstool steel, chrome, brass and wood 65 cm

EN 1022:2005 and EN 16139:2013. Level 2

ANSI/BIFMA X5.4-2012

Form barstool steel, chrome, brass and wood 75 cm

EN 1022:2005 and EN 16139:2013. Level 2

ANSI/BIFMA X5.4-2012

Form barstool stacking steel and chrome 65 cm

EN 1022:2005 and EN 16139:2013. Level 2

Form barstool stacking steel and chrome 75 cm

EN 1022:2005 and EN 16139:2013. Level 2

ANSI/BIFMA X5.4-2012



Form armchair swivel 4L full upholstery aluminum



Form chair full upholstery walnut

Product options

Shell



White Grey Black Blue Green Red

Wood legs

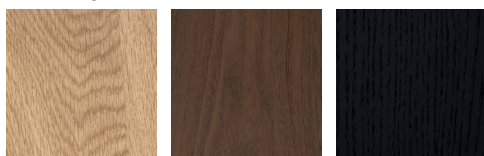

Oak Walnut Black

Steel legs



White Grey Black Blue Green Red Brass Chrome

Swivel 4L / Swivel 5W gaslift



Aluminum Black

Stacking base



White Grey Black Blue Green Red Chrome

Upholstery (all available in several colors)

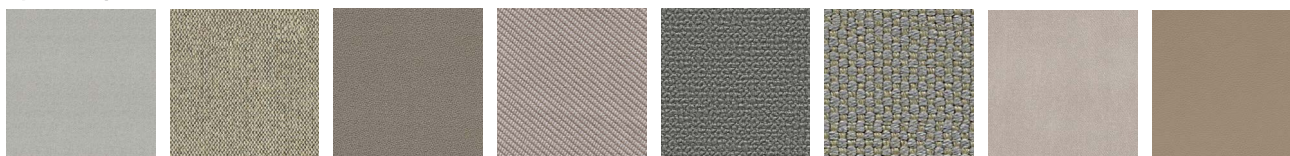

Camira Synergy Camira Main Line Flax Camira Aquarius Camira Oceanic Camira Yoredale Camira Zap JAB City Velvet Sørensen Leather Ultra



Above:
Form barstool 65 cm full upholstery oak



Above right:
Form armchair swivel 5W gaslift aluminum



Form barstool 65 cm full upholstery brass,
Form barstool 75 cm full upholstery brass



Just chair full upholstery chrome

Just chair

A simple and understated chair

Just is a simple and understated stackable shell chair with lots of personality and character that is as beautiful when seen from below as from above. The frame is discretely tucked into the chair's molded shell, and the shell's tapering thickness gives it a friendly and welcoming expression. When designing Just, the designer duo Iskos-Berlin looked to the essence of a chair. They started out with the shape of a chair as a child would typically draw it, with legs that seem to protrude directly out of the seat. They have transferred this visual effect to the Just Chair, where a steel frame is uniquely countersunk into the underside of the shell, suddenly transforming the chair into a harmonic and naturally unified whole. The chair fits into most furniture schemes and is ideal both around the dinner table and in the kitchen.

Collection

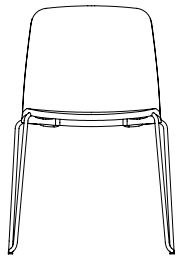

Just chair steel, chrome
H: 79 x L: 53 x D: 53 x SH: 45 cm

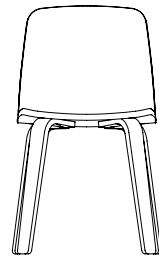

Just chair wood
H: 80 x L: 47,5 x D: 53,5 x SH: 45 cm

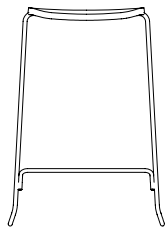

Just bar stool 65 cm steel, chrome
H: 65 x L: 46,5 x D: 40 x SH: 65 cm

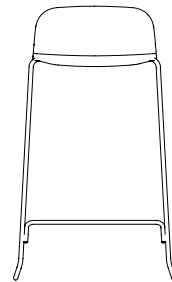

Just bar stool 65 cm w. back steel, chrome
H: 80 x L: 46,5 x D: 42 x SH: 65 cm

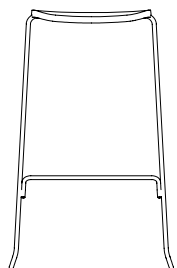

Just bar stool 75 cm steel, chrome
H: 75 x L: 47,5 x D: 44 x SH: 75 cm

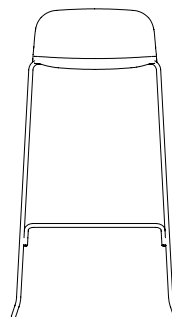

Just bar stool 75 cm w. back steel, chrome
H: 90 x L: 47,5 x D: 44 x SH: 75 cm



Just chair full upholstery steel



Just chair oak



Just bar stool 65 cm w. back full upholstery steel



Just chair black ash

Product facts and options

Description

Just chair oak has inherited the characteristic molded shell of the Just chair. It is joined by molded wooden legs, which grow from the shell in the same resolute curve that can be seen in the arch of the seat. The outward-sloping wooden legs add a charming warmth and emphasis to the design.

Designer / Year Of Design

Iskos-Berlin / 2014

Material

Shell: Lacquered oak veneer / Painted and lacquered ash veneer

Upholstery: PU foam with front or full upholstery

Legs: Powder coated steel, chrome

Construction

Just consists of a shell made of molded ash veneer with PU foam and textile or leather upholstery. The chair has a chrome frame mounted to the seat by slotting seamlessly into the millings underneath the shell.

Stackability

The Just chair version with chrome and steel legs and the Just barstool are stackable up to 6 pcs. We do not recommend stacking the front upholstery or full upholstery versions, as the weight of the chairs could leave marks on the upholstery. The chair is delivered assembled.

Accessories

Comes with plastic (PE) glides.

Felt glides can be purchased separately.

Test

Just chair steel

EN 1022:2005 and EN 16139:2013. Level 1

Shell

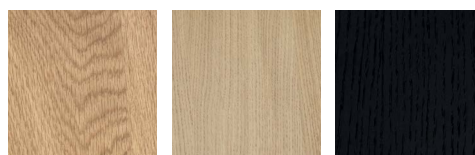

Oak

Ash

Black ash

Wood legs

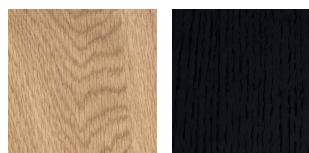
Oak
(w. oak shell)Black ash
(w. black ash shell)

Steel legs



Chrome

Black

Upholstery - steel legs versions only (all available in several colors)

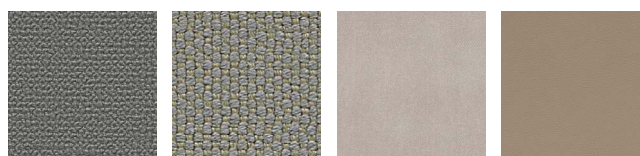
Camira
SynergyCamira
Main Line FlaxCamira
AquariusCamira
OceanicCamira
YoredaleCamira
ZapJAB
City VelvetSørensen Leather
Ultra



Hyg chair steel

Hyg

Soft lines and
encircling contours

Inspired by Danish hygge, designer Simon Legald has created a contemporary multipurpose chair series that performs as impeccably in comfort and endurance, as it does in adding warmth and ambiance to the interior. With its hearty, welcoming expression and resilient construction, the Hyg chair and barstool can adopt a wide range of expressions. Designed to provide support according to body contours, the Hyg chair places itself somewhere between chair and armchair with a shape that gently embraces you while allowing for freedom of movement.

Collection

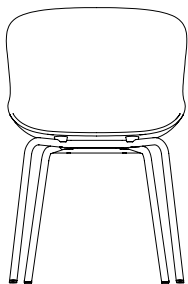

Hyg chair steel

H: 84 x L: 54 x D: 55,5 x SH: 46 cm

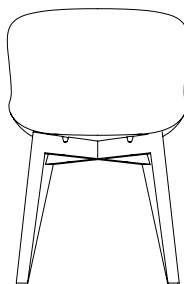

Hyg chair wood

H: 84 x L: 54 x D: 53,5 x SH: 46 cm

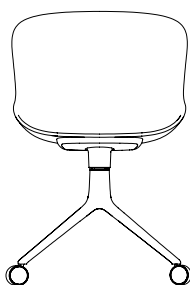

Hyg chair swivel 4W

H: 84 x L: 54 x D: 55,5 x SH: 46 cm

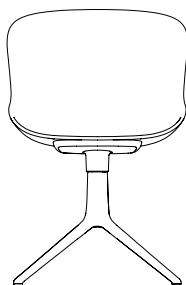

Hyg chair swivel 4L

H: 84 x L: 54 x D: 55,5 x SH: 46 cm

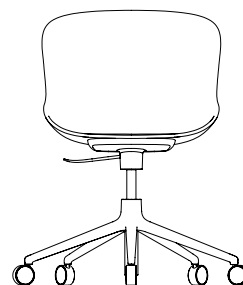

Hyg chair swivel 5W gaslift

H: 70/83 x L: 72 x D: 72,5 x SH: 37/50 cm

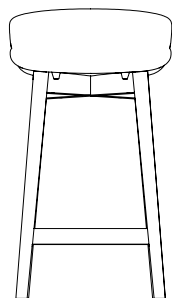

Hyg bar stool 65 cm wood

H: 84 x L: 46,5 x D: 44 x SH: 65 cm

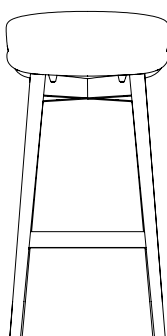

Hyg bar stool 75 cm wood

H: 94 x L: 46,5 x D: 46,5 x SH: 75 cm

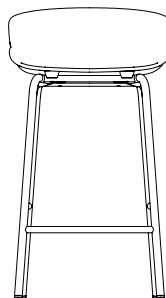

Hyg bar stool 65 cm steel

H: 84 x L: 46,5 x D: 45 x SH: 65 cm

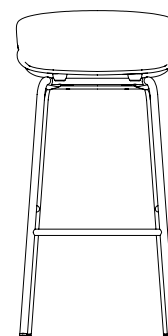

Hyg bar stool 75 cm steel

H: 94 x L: 46,5 x D: 47,5 x SH: 75 cm



Hyg chair swivel 4L full upholstery aluminum



Hyg chair swivel 4L full upholstery aluminum





Hyg barstool 65 cm full upholstery steel

Product facts and options

Description

With its hearty, welcoming expression and resilient construction, the Hyg chair is a great match for both domestic settings and contract use. Designed to provide support according to body contours, the Hyg chair places itself somewhere between chair and armchair with a shape that gently embraces you while allowing for freedom of movement.

Designer / Year Of Design

Simon Legald / 2019

Material

Shell: Polypropylene

Upholstery: PU foam with front or full upholstery

Legs: Powder coated steel / Aluminum

Construction

A shell of high-strength polypropylene is mounted on a steel or aluminum base. The steel legs match the color of the shell seat. Both chair and barstool are available with front upholstery or full upholstery. Hyg is delivered assembled.

Accessories

Comes with PE glides. Felt glides can be purchased separately. See Glides Overview.

Test

Hyg chair steel

EN 1022:2005 and EN 16139:2013. Level 2

Hyg barstool steel

EN 1022:2005 and EN 16139:2013. Level 2

Shell and steel legs



White

Grey

Black

Olive



Sand

Swivel 4 legs / Swivel 4 wheels / Swivel 5 wheels gaslift



Aluminum

Black

Wood legs

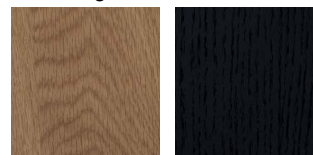

Oak

Black Oak

Front / Full upholstery (all available in several colors)



Camira
Synergy

Camira
Main Line Flax

Camira
Aquarius

Camira
Oceanic

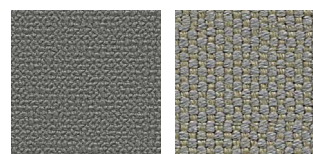

Camira
Yoredale

Camira
Zap

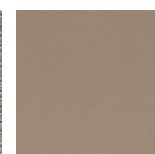

Sørensen Leather
Ultra



Hyg bar stool 75cm front upholstery steel,
Hyg bar stool 65 cm full upholstery steel,
Hyg bar stool 65 cm steel

Hyg chair swivel 5W gaslift full upholstery aluminum





My Chair walnut

My Chair

Uncompromising design
and impeccable comfort

Effortless and timeless, Nicholai Wiig Hansen's My Chair from 2013 is as close as it gets to a new classic: a minimalistic chair in molded veneer that moves gently with the body. The curved waist and rounded corners counterbalance the stringent design of the chair and give it a warm and welcoming feel. Due to its harmonious silhouette, My Chair complements most settings and can be multiplied without taking over the interior.





My Chair in various combinations



My Chair full upholstery chrome

Collection

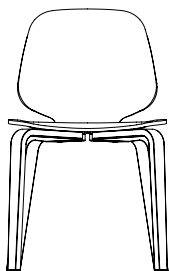

My Chair wood

H: 80 x L: 48 x D: 50 x SH: 44 cm

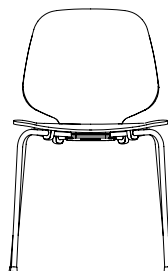

My Chair steel, chrome

H: 80 x L: 50 x D: 54 x SH: 43,5 cm

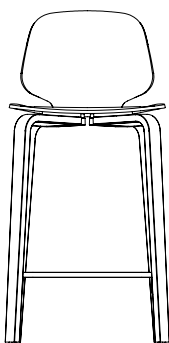

My Chair bar stool 65 cm wood

H: 93 x L: 45,5 x D: 48 x SH: 65 cm

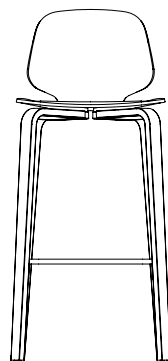

My Chair bar stool 75 cm wood

H: 102,5 x L: 46,5 x D: 49 x SH: 75 cm

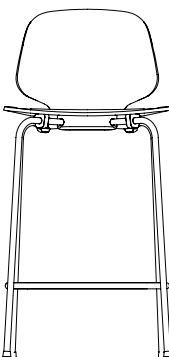

My Chair bar stool 65 cm, steel, chrome

H: 92,5 x L: 49 x D: 49,5 x SH: 65 cm

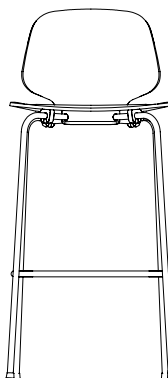

My Chair bar stool 75 cm, steel, chrome

H: 102,5 x L: 45 x D: 53 x SH: 75 cm

Product facts

Description

With My Chair, designer Nicholai Wiig Hansen has reinterpreted the classic shell chair, adding a striking elegance and harmony. The curved waist and rounded corners counterbalance the stringent design of the chair and give it a warm and welcoming feel.

Designer / Year Of Design

Nicholai Wiig Hansen / 2013

Material

Wood Shell Version

Shell: Lacquered veneer (Birch, Oak or Walnut) / Painted and lacquered oak veneer (Smoked Oak) / Painted and lacquered ash veneer (color versions)

Legs: Lacquered veneer (Birch, Oak or Walnut) / Painted and lacquered oak veneer (Smoked Oak) / Painted and lacquered ash veneer (color versions) / Chrome / Powder coated steel

Front Upholstery Version

Shell: Lacquered veneer (Birch, Oak or Walnut) / Painted and lacquered oak veneer (Smoked Oak) / Painted and lacquered ash veneer (color versions)

Upholstery: PU foam with front upholstery

Legs: Lacquered veneer (Birch, Oak or Walnut) / Painted and lacquered oak veneer (Smoked Oak) / Painted and lacquered ash veneer (color versions) / Chrome / Powder coated steel

Full Upholstery Version

Shell: Birch veneer

Upholstery: PU foam with full upholstery

Legs: Lacquered veneer (Birch, Oak or Walnut) / Painted and lacquered oak veneer (Smoked Oak) / Painted and lacquered ash veneer (color versions) / Chrome / Powder coated steel

Construction

The chair is delivered assembled. For the versions in wood and front upholstery, the shell and back shell material always match the legs' material e.g. both shell and legs come in lacquered oak veneer. My Chair bar stool is delivered with a chrome foot support. Black foot support is available upon request.

Stackability

My Chair with steel or chrome legs is stackable up to 8-10 pcs. We do not recommend stacking the front upholstery or full upholstery versions, as the weight of the chairs could leave marks on the upholstery. Compatible with our Chair Rack. Stackable up to 15 chairs on our single version Chair Rack and up to 30 on our double version Chair Rack.

Accessories

Comes with PE glides. Felt glides can be purchased separately. See Glides Overview.

My Chair steel and chrome can be connected with Chair Link. Compatible with our Chair Suspension.

Test

My chair steel and wood
EN 1022:2005 and EN 16139:2013. Level 1



My Chair bar stool 65 cm wood,
My Chair bar stool 75 cm wood



My Chair oak

Product options

Shell and legs

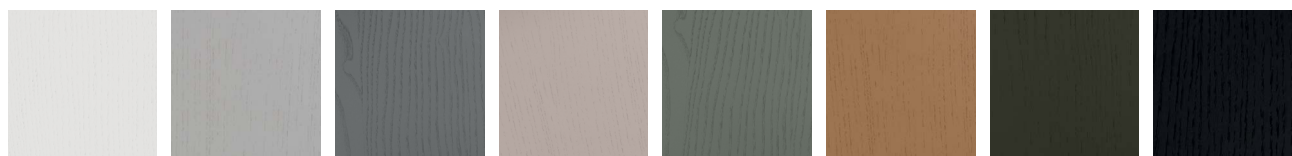

White

Light grey

Grey

Oyster

Dusty green

Sandstone

Moss

Black

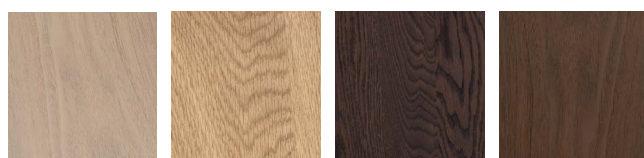

Birch

Oak

Smoked oak

Walnut

Steel legs



Chrome

Black

Front / Full upholstery (all available in several colors)



Camira
Synergy

Camira
Main Line Flax

Camira
Aquarius

Camira
Oceanic

Camira
Yoredale

Camira
Zap

Sørensen Leather
Ultra



Knot chair black / nature

Knot

Comfort for both body and eye

The Japanese designer Tatsuo Kuroda has created a chair which unites classic materials with modern aesthetics. With a clean and simple expression, the Knot chair leads the thoughts to classic 1950s furniture. The structural components of the chair are tied together with paper cord, which provide both support and a stylish visual expression; and, despite Kuroda's Japanese background, he has been inspired by traditional Scandinavian design. The result is comfort for both body and eye.

Collection

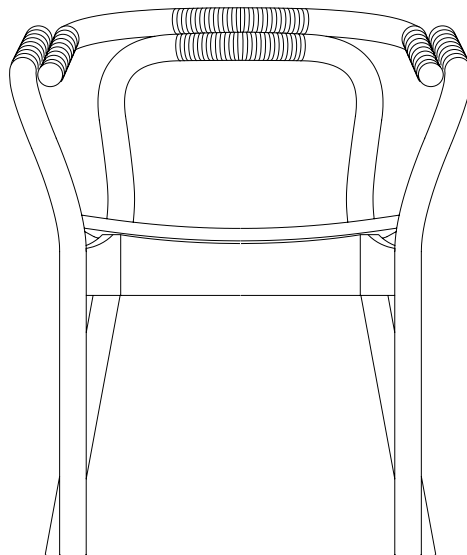

Knot chair

H: 72 x L: 58,5 x D: 50,5 x SH: 43 x AR: 65,5-68,5 cm

Knot chair white / white





Knot chair black / black

Product facts and options

Description

The Knot chair is an elegant fusion of classic materials and modern aesthetics. The overall impression is determined by the details, such as the dominant jointing points in natural paper cord, which also provide optimal sitting comfort.

Designer / Year Of Design

Tatsuo Kuroda / 2012

Material

Painted and lacquered ash veneer / Paper cord

Construction

Knot chair is made from solid wood that is bent into shape and equipped with a seat of curved veneer. The overlapping of the bent wood components creates a wider armrest and the meeting points are tied together with natural paper cord. The chair is delivered assembled.

Accessories

Comes with PP glides. Felt glides can be purchased separately. See Glides Overview.

Test

EN 1022:2005 and EN 16139:2013. Level 2

Colors



White / white



Black / black



Black / natural

Herit armchair upholstery smoked oak



Herit

Uniting the eras of Danish design

Danish design traditions have left a clear mark on Simon Legald's chair series, Herit, which is short for heritage. The series reflects his love of classic Danish furniture craftsmanship and rose from a desire to design a versatile and strong chair that unites the different eras of Danish design. A chair in which oak and polypropylene merge in tactful synergy to create a hard-wearing, maintenance-friendly and accessible design made for modern life.

Collection

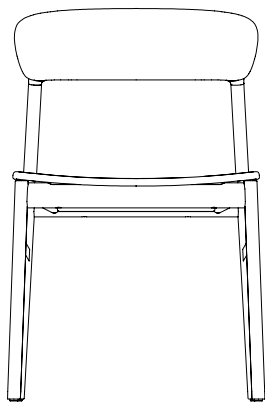

Herit chair

H: 78,5 x W: 50 x D: 51 x SH: 45 cm

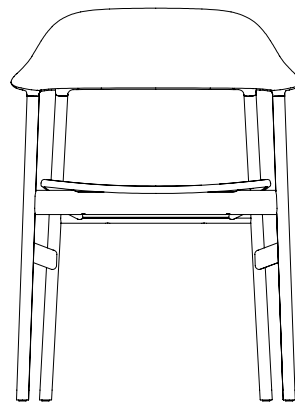

Herit armchair

H: 81,5 x L: 60 x D: 51 x SH: 45 x AR: 66,5-77 cm



Herit chair and armchair in various combinations



Herit chair black oak,
Herit chair upholstery black oak

Product facts and options

Description

The simple and honest style that characterizes Danish furniture history stands as a clear frame of reference for the Herit series. However, Herit is just as much a design that looks forward. Innovative production methods, new material compositions and timeless silhouettes give life to a chair that stands tall on its own.

Designer / Year Of Design

Simon Legald / 2018

Material

Shell: Polypropylene, PU foam with upholstery
Legs: Lacquered oak / Painted and lacquered oak

Construction

The polypropylene parts are molded with a core of foam. This innovative technique makes it possible to create thickness in the needed areas in order to obtain the best seating comfort and construct the sweeping lines of the design. The legs are made of solid wood. Herit comes assembled.

Accessories

Comes with PE glides. Felt glides can be purchased separately. See Glides Overview.
Herit chair is compatible with our Chair Suspension.

Test

Herit chair
EN 1022:2005 and EN 16139:2013. Level 2
Herit armchair
EN 1022:2005 and EN 16139:2013. Level 2

Shell / backrest



White

Grey

Black

Sand



Dusty green

Legs

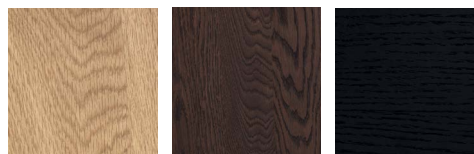

Oak

Smoked oak

Black oak
(only available with
black shell / backrest)

Seat upholstery

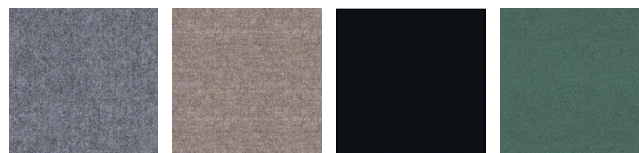

Grey backrest:
Camira Synergy
LDS16

Sand backrest:
Camira Synergy
LDS32

Black backrest:
Camira Synergy
LDS27

Dusty green backrest:
Camira Synergy
LDS49

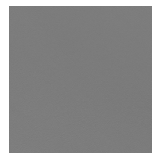

Grey backrest:
Sørensen Leather
Spectrum Silver
Grey 30130



Sand backrest:
Sørensen Leather
Spectrum Marble
30105

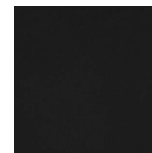

Black backrest:
Sørensen Leather
Spectrum Black
30114



Dusty green backrest:
Sørensen Leather
Spectrum Dusty green
30098

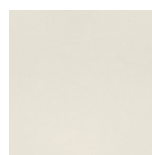

White backrest:
Sørensen Leather
Spectrum White
30140



Ace chair upholstery steel

Ace

Balancing the refined and relaxed

Suitable for both private settings and public spaces, the Ace furniture range stands out for its friendly, organic lines in a design of timeless and nonchalant elegance. With their high backrest and luxurious upholstery, the Ace chair and bar chair offer comfort to sit for hours at a time, ideal for dining or long meetings. The upholstery is an essential component of the Ace range and is carried out by skilled upholsterers, who practice their craft with precision. Rounded contours emphasize the inviting volume of the full upholstery and are framed elegantly by the piping around the seat and back.





Ace series in various combinations

Collection

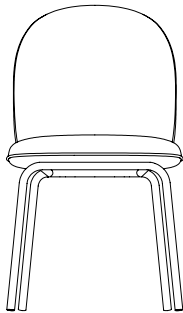

Ace chair
upholstery steel
H: 80,5 x L: 46 x D: 52,5 x SH: 47 cm

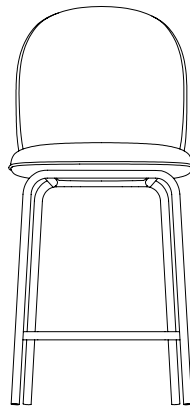

Ace bar chair 65 cm
upholstery steel
H: 98,5 x L: 45 x D: 50,5 x SH: 65 cm

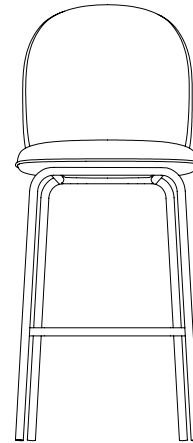

Ace bar chair 75 cm
upholstery steel
H: 108,5 x L: 46 x D: 52,5 x SH: 75 cm



Ace chair upholstery steel



Above:
Ace bar chair 75 cm upholstery steel

Above right:
Ace chair upholstery steel

Product facts and options

Description

The Ace series aims at urban dwellers, who prioritize quality and aesthetics but who must also adapt to the limited space of life in the city. With a recurring design trait of friendly, organic lines, the Ace range offers maximum comfort in condensed form.

Designer / Year Of Design

Hans Hornemann / 2016

Material

Shell: Veneer with PU foam, steel reinforcement upholstery
Legs: Powder coated steel

Construction

Ace has a backrest constructed from molded PU foam on a base of molded veneer for flexibility and the highest possible sitting comfort. The seat is made of molded PU foam with a steel reinforcement.

Accessories

Comes with PE/POM glides. Felt glides can be purchased separately. See Glides Overview.

Steel legs



Black

Upholstery (all available in several colors)



Camira
Synergy



Camira
Main Line Flax



Camira
Aquarius

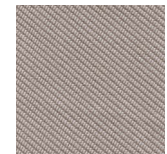

Camira
Oceanic

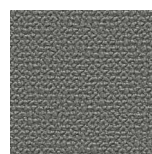

Camira
Yoredale



Camira
Zap



JAB
City Velvet



Sørensen Leather
Ultra



Studio armchair full upholstery steel

Studio

An industrial and airy design

There is something virtually graphic about the way the slender steel frame grows out below the seat and back of the Studio chair, framing the molded shell in an airy design. The flowing lines stand out in an eye-catching silhouette, like a line drawing or pictogram, just as the empty spaces between the frame and the back act to define the shape. The simple construction in veneer and steel tubing leads the mind to older French factory chairs, giving Studio its industrial notes. A design that attracts attention, but glows with pure simplicity.



Studio bar stool 65 cm front upholstery steel,
Studio bar chair 75 cm steel,
Studio chair full upholstery steel

Right:
Studio armchair steel

Below:
Studio chair full upholstery steel



Collection

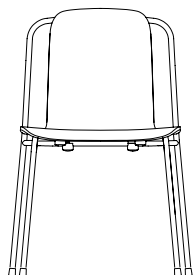

Studio chair steel
H: 81 x L: 60 x D: 57,5 x SH: 44 cm

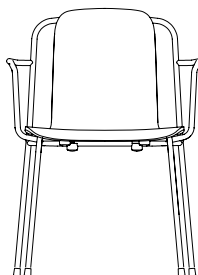

Studio armchair steel
H: 81 x L: 60 x D: 57,5 x SH: 44 cm

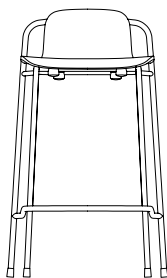

Studio bar stool 65 cm steel
H: 80 x L: 48 x D: 47 x SH: 65 cm

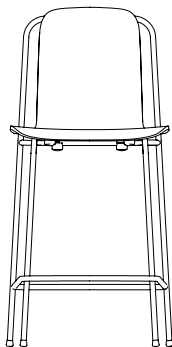

Studio bar chair 65 cm steel
H: 103 x L: 51 x D: 57 x SH: 65 cm

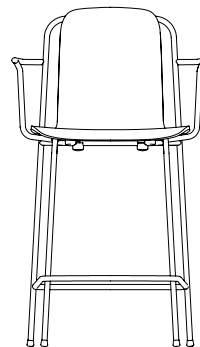

Studio bar armchair 65 cm steel
H: 103 x L: 60 x D: 57 x SH: 65 x AR: 87,5 cm

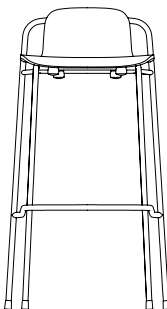

Studio bar stool 75 cm steel
H: 90 x L: 48 x D: 47 x SH: 75 cm

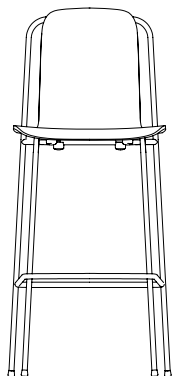

Studio bar chair 75 cm steel
H: 113 x L: 52 x D: 57 x SH: 75 cm

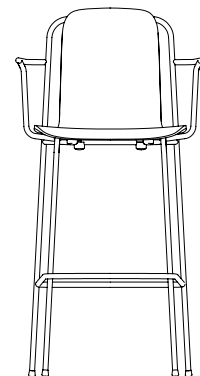

Studio bar armchair 75 cm steel
H: 113 x L: 60 x D: 57 x SH: 75 x AR: 97,5 cm



Studio armchair front upholstery steel



Studio series in various combinations

Product facts and options

Description

Studio is a multi-purpose, stackable chair series with references to French industrial design. The combination of veneer and black steel conveys a graphic freshness and a contemporary, modern look.

Designer / Year Of Design

Simon Legald / 2018

Material

Shell: Lacquered oak veneer / Painted and lacquered ash veneer

Upholstery: PU foam with front or full upholstery

Legs: Powder coated steel

Construction

Studio is made from molded veneer. Comes in oak with a clear lacquer or in a painted ash veneer version. Legs are made of powder coated steel tubes.

Stackability

Studio Chair is stackable up to 14 pcs. We do not recommend stacking the front upholstery or full upholstery versions, as the weight of the chairs could leave marks on the upholstery. Compatible with our Chair Rack. Stackable up to 15 chairs on our single version Chair Rack and up to 30 on our double version Chair Rack.

Accessories

Comes with PE glides. Felt glides can be purchased separately. See Glides Overview.

Can be connected with Chair Link.

Compatible with our Chair Suspension.

Test

Studio Chair

EN 1022:2005 and EN 16139:2013 Level 2

Studio Chair

ANSI/BIFMA X5.4-2012

Studio Barstool

ANSI/BIFMA X5.1-2017

Shell

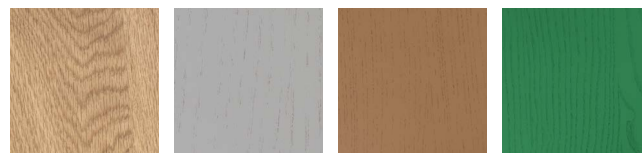

Oak

Light grey

Brown

Green

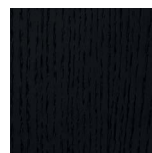

Black

Steel legs



Black

Front / Full upholstery (all available in several colors)



Camira
Synergy

Camira
Main Line Flax

Camira
Aquarius

Camira
Oceanic

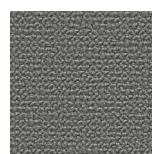

Camira
Yoredale



Camira
Zap

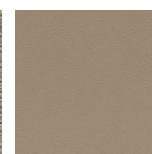

Sørensen Leather
Ultra



Timb armchair black

Timb

Honest design and logical construction

Timb is the fundamental essence of a chair whose clean and humble design emerges from its function, which is why designer Simon Legald considers his new wooden chair to be a particularly meaningful addition to Normann Copenhagen's collection of dining chairs. The name Timb is an expression of the chair's simple vision for the value of its material. The Timb chair's humble nature allows the design to blend easily and elegantly into almost any environment, yielding space to other more prominent elements of the interior. The solid craftsmanship is visible from all angles, and there is a distinct structure to its shape that also allows for repetition, making Timb an excellent choice not just for the home but for cafés, restaurants, cafeterias and educational institutions as well. A wooden chair for all.

Collection

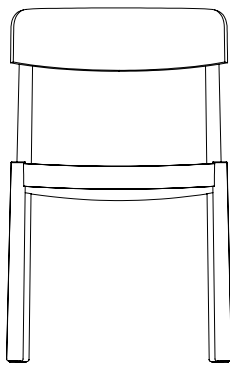

Timb chair
H: 82 x L: 52 x D: 51 x SH: 46 cm

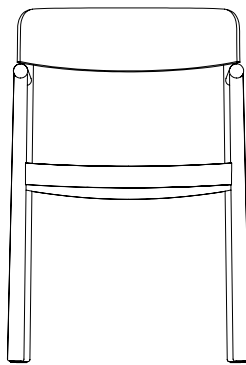

Timb armchair
H: 82 x L: 56 x D: 51,5 x SH: 46 x AR: 69 cm

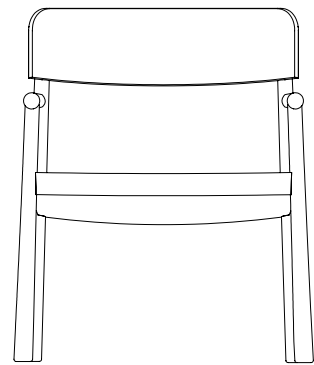

Timb lounge armchair
H: 75,5 x L: 67 x D: 62 x SH: 42 cm x
AR: 58 cm

Timb chair upholstery tan,
Timb armchair upholstery tan





Timb series in various combinations





Timb armchair upholstery tan,
Timb chair tan

Product facts and options

Description

The Timb chair has a simple wooden structure with a richness of detail in the contrast between its curves and sharp lines. Its artisan traditions are also visible in its elegant dowel joints, which make it possible to manufacture the chair without the need for screws, allowing the wood itself to act as focal point. Timb is available in a golden brown (tan) or black lacquered edition, either with or without armrests.

Designer / Year Of Design

Simon Legald / 2020

Material

Frame: Painted and lacquered ash

Seat and back: Painted and lacquered ash veneer

Upholstery: PU foam and Ultra leather

Construction

The Timb chair comprises a frame of solid painted and lacquered ash and a wide, comfortable seat and backrest made from painted and lacquered ash veneer. The chair has a dowel joint construction with no need for screws. Timb is delivered assembled.

Accessories

Comes with POM glides. Felt glides can be purchased separately. See Glides Overview.

Test

Timb chair

EN 1022:2005 and EN 16139:2013. Level 2

Timb armchair

EN 1022:2005 and EN 16139:2013. Level 2

Frame, seat and backrest

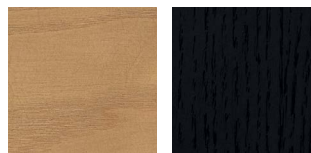

Tan

Black

Seat and backrest upholstery



Tan frame:
Sørensen Leather
Ultra Camel

Black frame:
Sørensen Leather
Ultra Black



Sofas & lounge chairs

Delve into soft curves and upholstered volume and let it set the scene for immersive spaces that help you focus or unwind.

Charismatic silhouettes, outstanding comfort and resilient constructions make our lounge luxuries equally fit for hospitality and leisure, informal business meetings, or for introducing an element of sensibility to a streamlined corporate environment.



Ace sofa brass,
Ace lounge chair brass

Ace lounge

Balancing the refined and relaxed

The Ace series aims at urban dwellers, who prioritize quality and aesthetics but who must also adapt to the limited space of life in the city. With a recurring design trait of friendly, organic lines, Ace offers maximum comfort in condensed form. Designer Hans Hornemann has worked on a chair's basic components – backrest, seat and legs – and has created a functional and aesthetic design with a more petite stature than traditional lounge furniture. The design balances finely between the refined and the relaxed. Rounded contours emphasize the inviting volume of the full upholstery and are framed elegantly by the piping around the seat and back. A backward-leaning backrest and cheekily angled legs give edge and attitude, resulting in a design of timeless and nonchalant elegance.

Collection

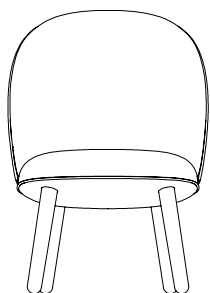

Ace lounge chair wood
H: 80 x L: 56 x D: 70 x SH: 41 cm

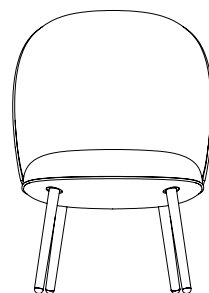

Ace lounge chair brass, black metallic
H: 80 x L: 56 x D: 70 x SH: 41 cm

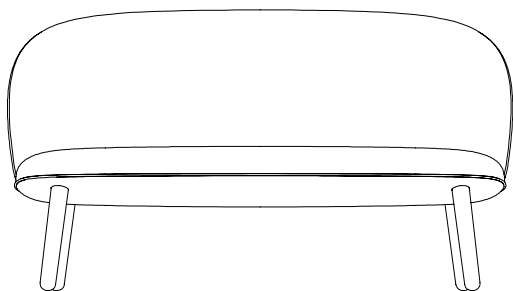

Ace sofa wood
H: 81 x L: 145 x D: 75 x SH: 41 cm

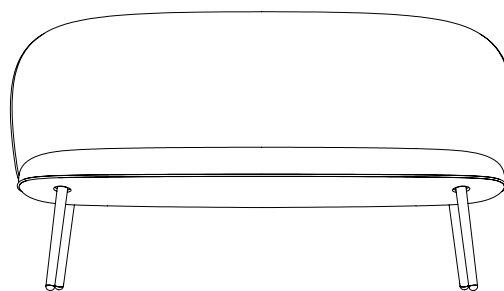

Ace sofa brass, black metallic
H: 81 x L: 145 x D: 75 x SH: 41 cm

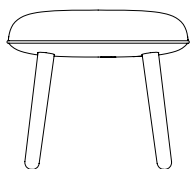

Ace footstool wood
H: 39 x L: 45 x D: 45 cm

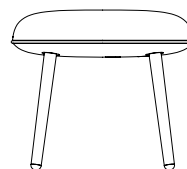

Ace footstool brass, black metallic
H: 39 x L: 45 x D: 45 cm



Above:
Ace lounge chair brass

Right:
Ace sofa brass,
Ace footstool brass





Ace sofa black oak

Product facts and options

Description

The Ace series aims at urban dwellers, who prioritize quality and aesthetics but who must also adapt to the limited space of life in the city. With a recurring design trait of friendly, organic lines, the Ace range offers maximum comfort in condensed form.

Designer / Year Of Design

Hans Hornemann / 2016

Material

Shell: Veneer, PU foam, steel reinforcement with upholstery
Legs: Lacquered oak / Painted and lacquered oak / Brass plated steel / Black plated steel

Construction

The back is constructed of molded PU foam on a base of molded veneer for flexibility and the highest possible sitting comfort. The seat is made in molded PU foam with a steel reinforcement. Available in textile or leather upholstery. Ace is easily assembled and assembly manual is included.

Accessories

Comes with PE glides. Felt glides can be purchased separately. See Glides Overview.

Test

Ace lounge chair and sofa
EN 1022:2005 and EN 16139:2013. Level 2

Wood legs

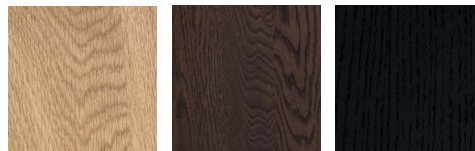

Oak

Smoked oak

Black

Steel legs

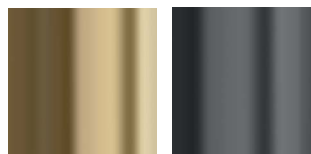

Brass

Black metallic

Upholstery (all available in several colors)

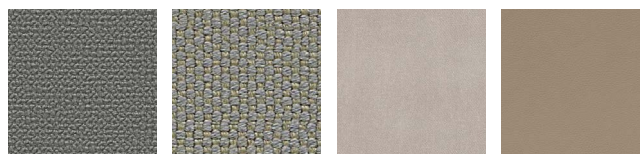
Camira
SynergyCamira
Main Line FlaxCamira
AquariusCamira
OceanicCamira
YoredaleCamira
ZapJAB
City VelvetSørensen Leather
Ultra



My Chair lounge oak,
My Chair lounge oak front upholstery

My Chair lounge

Effortless and timeless design

Effortless and timeless, Nicholai Wiig Hansen's My Chair from 2013 is as close as it gets to a new classic: a minimalistic chair in molded veneer that moves gently with the body. The curved waist and rounded corners counterbalance the stringent design of the chair and give it a warm and welcoming feel. Due to its harmonious silhouette, My Chair complements most settings and can be multiplied without taking over the interior.

Collection

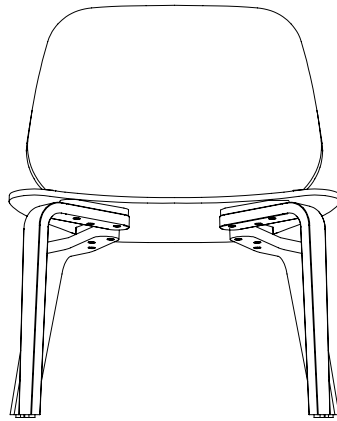

My Chair lounge

H: 72 x L: 58 x D: 67 x SH: 38,5 cm



My Chair lounge birch,
My Chair lounge birch front upholstery



My Chair lounge birch

Product facts

Description

My Chair lounge continues My Chair's characteristic back in a chair with a lower seat height. Lowered towards the floor in a reclining posture, it forms a balanced and sophisticated design, eminently suitable for spaces that require a lighter lounge chair.

Designer / Year Of Design

Nicholai Wiig Hansen / 2013

Material

Wood shell version

Shell: Lacquered veneer (birch, oak or walnut) / Painted and lacquered oak veneer (smoked oak) / Painted and lacquered ash veneer (color versions)

Legs: Lacquered veneer (birch, oak or walnut) / Painted and lacquered oak veneer (smoked oak) / Painted and lacquered ash veneer (color versions)

Front upholstery version

Shell: Lacquered veneer (birch, oak or walnut) / Painted and lacquered oak veneer (smoked oak) / Painted and lacquered ash veneer (color versions)

Upholstery: PU foam with front upholstery

Legs: Lacquered veneer (birch, oak or walnut) / Painted and lacquered oak veneer (smoked oak) / Painted and lacquered ash veneer (color versions)

Full upholstery version

Shell: Birch veneer

Upholstery: PU foam with full upholstery

Legs: Lacquered veneer (birch, oak or walnut) / Painted and lacquered oak veneer (smoked oak) / Painted and lacquered ash veneer (color versions)

Construction

The chair is delivered assembled. For the versions in wood, the shell and back shell material always match the legs' material e.g. both shell and legs come in lacquered oak veneer.

Accessories

Comes with PE glides. Felt glides can be purchased separately. See Glides Overview.

Test

My Chair lounge

EN 1022:2005 and EN 16139:2013. Level 2

Product options

Shell and legs

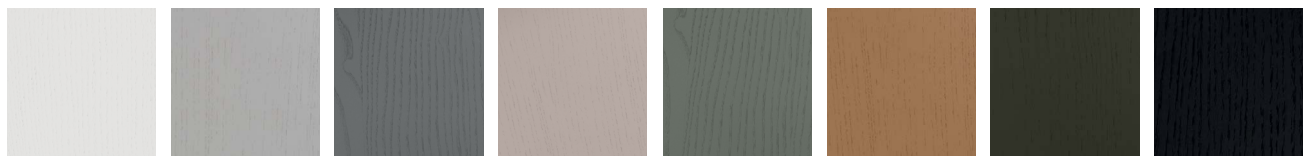

White

Light grey

Grey

Oyster

Dusty green

Sandstone

Moss

Black

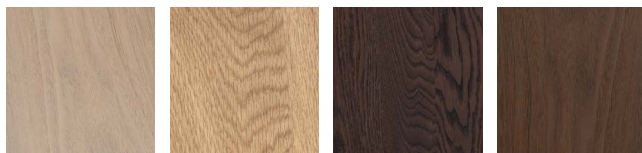

Birch

Oak

Smoked oak

Walnut

Front / Full upholstery (all available in several colors)



Camira
Synergy

Camira
Main Line Flax

Camira
Aquarius

Camira
Oceanic

Camira
Yoredale

Camira
Zap

Sørensen Leather
Ultra



My Chair lounge in various combinations



Era lounge chair low chrome

Era

The art of refined proportions

The design is well-proportioned, the lines are sharp and the feel is contemporary. Expressing a sophisticated calmness that invites the sitter to pure and unreserved relaxation, Era demonstrates the art of refined proportions. A design in which the interaction between soft curves and straight lines is done just right. An incredibly strong construction makes the Era series well-suited for commercial spaces. The same level of care proceeds to the upholstery and stitching, which are carried out with the utmost artisanal precision to flawlessly dress the sleek silhouettes. With its streamlined design and high quality, Era is designed to transcend generations.

Collection

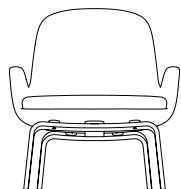

Era lounge chair low wood
H: 77 x L: 72 x D: 75 x SH: 40 cm

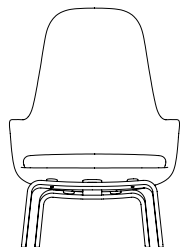

Era lounge chair high wood
H: 103 x L: 72 x D: 80 x SH: 40 cm



Era footstool wood
H: 39 x L: 53 x D: 42 x SH: 39 cm



Era lounge chair low steel, chrome
H: 77 x L: 72 x D: 75 x SH: 40 cm

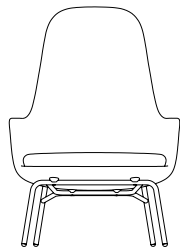

Era lounge chair high steel, chrome
H: 103 x L: 72 x D: 80 x SH: 40 cm



Era footstool steel, chrome
H: 39 x L: 53 x D: 42 x SH: 39 cm



Era lounge chair low swivel aluminum
H: 77 x L: 83 x D: 83 x SH: 40 cm

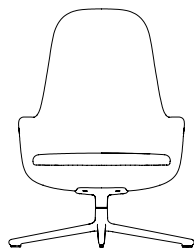

Era lounge chair high swivel aluminum
H: 103 x L: 83 x D: 83 x SH: 40 cm



Era footstool swivel aluminum
H: 39 x L: 53 x D: 42 x SH: 39 cm

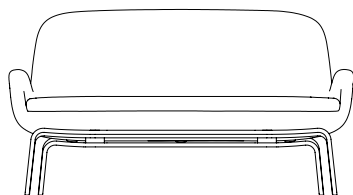

Era sofa wood
H: 78 x L: 145 x D: 77 x SH: 41 cm

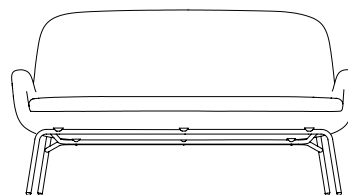

Era sofa steel, chrome
H: 78 x L: 145 x D: 77 x SH: 41 cm



Era lounge chair low steel



Era lounge chair low oak

Product facts and options

Description

Era combines modern production techniques with traditional furniture craftsmanship in a timeless and characterful design. The Era series includes a high and low version of lounge chairs, a 2 seater sofa and a footstool with multiple base types for a great variety.

Designer / Year Of Design

Simon Legald / 2014

Material

Shell: Hard molded PU foam with steel reinforcement

Cushion: Soft molded PU foam with upholstery

Base: Powder coated steel, oak veneer, walnut veneer, chrome, lacquered oak veneer, aluminum, powder coated aluminum

Construction

The shell has a steel reinforcement for added strength.

Era is delivered assembled.

Accessories

Comes with PE glides. Felt glides can be purchased separately. See Glides Overview.

Test

Era lounge chair steel & chrome

EN 1022:2005 and EN 16139:2013. Level 2

ANSI/BIFMA X5.4-2012

Era lounge chair wood

EN 1022:2005 and EN 16139:2013. Level 2

Era lounge chair swivel

EN 1022:2005 and EN 16139:2013. Level 2

Era sofa steel, chrome and wood

EN 1022:2005 and EN 16139:2013. Level 2

Wood legs



Oak

Walnut

Black oak

Steel legs



Chrome

Black

Swivel



Aluminum

Black aluminum

Upholstery (all available in several colors)



Camira
Synergy

Camira
Main Line Flax

Camira
Aquarius

Camira
Oceanic

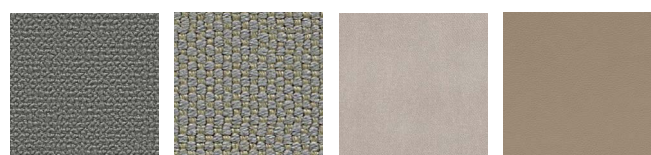

Camira
Yoredale

Camira
Zap

JAB
City Velvet

Sørensen Leather
Ultra



Era sofa steel



Era lounge chair high swivel aluminum



Hyg lounge chair high swivel aluminum

Hyg lounge

Exclusive lounge series
inspired by "hygge"

No other word in the Danish language has become as internationally celebrated as "hygge". "Hygge" is all about feeling good – security, warmth and comfort are all parts of its DNA, and it is precisely these qualities that provide the template for the Hyg lounge series. Hyg is an exclusive range, in which soft lines and encircling contours create a cozy and pleasant space. Characterized by its ample silhouette, Hyg radiates a primary organic purity. Its voluminous form is offset by a narrow contour which hones and refines its expression. High sides lightly shield off the room, while a wide seat makes it possible to assume a wide range of relaxed seating postures. The enveloping design can add a sense of security and privacy to a hectic environment, making the furniture eminently suitable for public spaces.

Hyg lounge chair low swivel aluminum





Left:
Hyg sofa oak

Below:
Hyg sofa oak

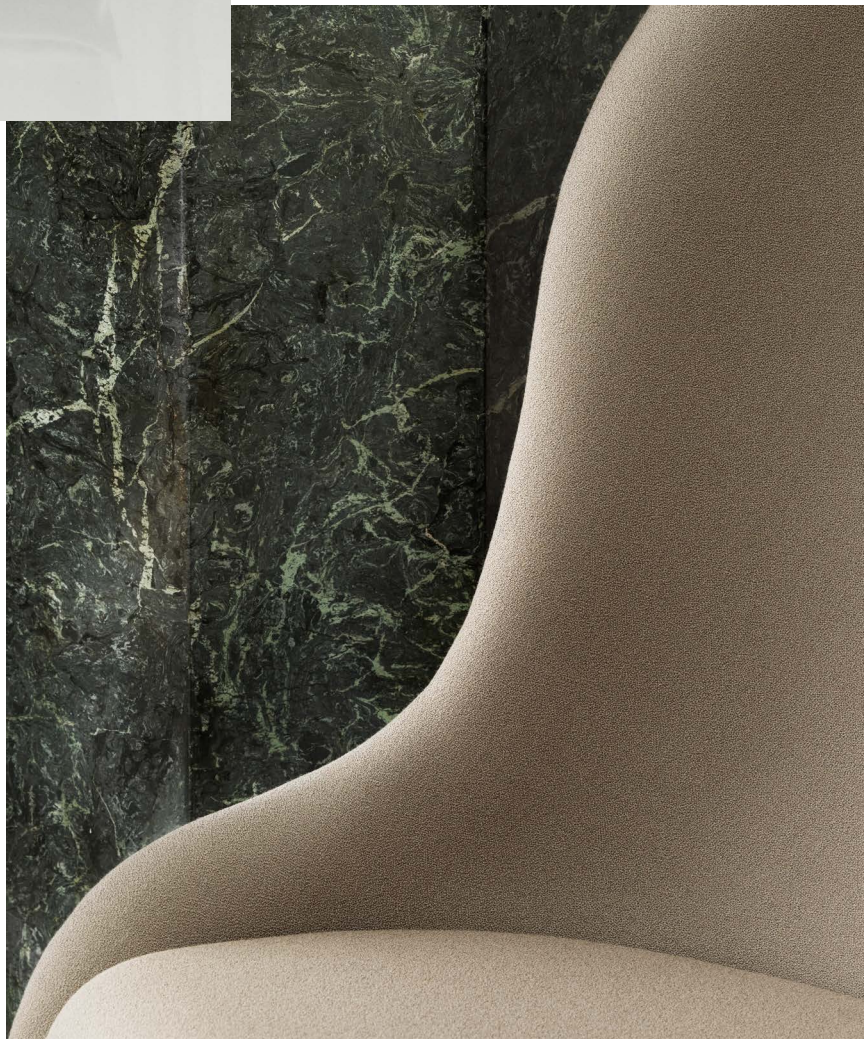





Hyg lounge series in various combinations

Collection

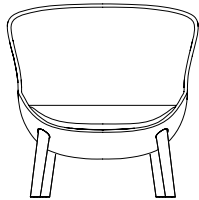

Hyg lounge chair low oak, black oak
H: 84,5 x L: 83 x D: 80 x SH: 40 cm



Hyg lounge chair low swivel
H: 84,5 x L: 83 x D: 80 x SH: 40 cm



Hyg lounge chair low swivel tilt
H: 84,5 x L: 83 x D: 80 x SH: 40 cm

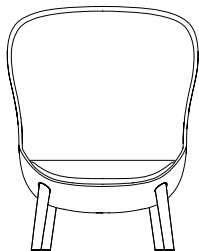

Hyg lounge chair high oak, black oak
H: 107,5 x L: 84,5 x D: 83,5 x SH: 40 cm

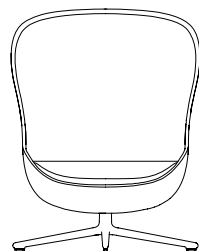

Hyg lounge chair low swivel
H: 107,5 x L: 84,5 x D: 83,5 x SH: 40 cm

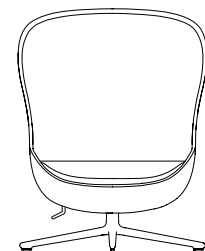

Hyg lounge chair low swivel tilt
H: 107,5 x L: 84,5 x D: 83,5 x SH: 40 cm

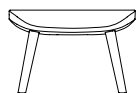

Hyg footstool oak, black oak
H: 39 x L: 62,5 x D: 48,5 x SH: 39 cm



Hyg footstool swivel
H: 39 x L: 62,5 x D: 48,5 x SH: 39 cm

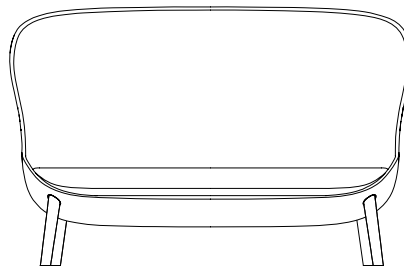

Hyg sofa oak, black oak
H: 107,5 x L: 168 x D: 86 x SH: 40 cm



Hyg lounge chair high swivel aluminum



Hyg lounge chair high swivel aluminum

Product facts and options

Description

With Hyg, Simon Legald has designed an exclusive range in which soft lines and encircling contours create a cozy and pleasant space. Hyg is made for hygge; a design that nourishes both the eye and the soul and which brings warmth and personality to any room.

Designer / Year Of Design

Simon Legald / 2018

Material

Shell: Hard molded PU foam with steel reinforcement

Cushion: Soft molded PU foam with upholstery

Legs: Lacquered oak, painted and lacquered oak

Swivel: Aluminum, powder coated aluminum

Construction

The shell has a steel reinforcement for added strength. Hyg is made of molded PU foam with a molded lumbar support. Hyg swivel high and low versions are available with tilt function. Hyg is delivered assembled.

Accessories

Comes with PE glides. Felt glides can be purchased separately. See Glides Overview.

Test

Hyg lounge chair wood

EN 1022:2005 and EN 16139:2013. Level 2

Wood legs

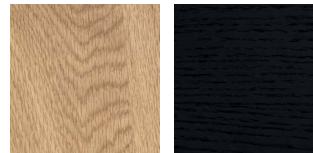

Oak

Black

Swivel



Aluminum

Black

Upholstery (all available in several colors)



Camira
Synergy

Camira
Main Line Flax

Camira
Aquarius

Camira
Oceanic



Camira
Yoredale

Camira
Zap

Sørensen Leather
Ultra



Sum modular sofa

Sum

The epitome of
contemporary elegance

Two, four, nine modules? Whatever the number, the sum is as follows: a well-proportioned sofa design that stands as the epitome of contemporary elegance. Sum is the name of our take on a light modular sofa, which has the same complete appearance whether it is set up in a two-seater version or as a several meter long lounge dream. The design is stringent and focused but invitingly open in character: elegant and resolute as a wingspread stretching out into the air, the sofa spreads out its armrests and invites you into its soft and homely space.



Sum modular sofa

Collection

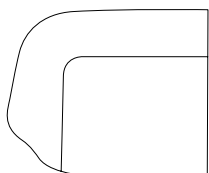

Sum modular sofa 100 left armrest
H: 76 x L: 91 x D: 76 x SH: 41 cm

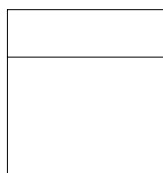

Sum modular sofa 110 center
H: 76 x L: 72,5 x D: 76 x SH: 41 cm

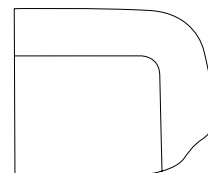

Sum modular sofa 120 right armrest
H: 76 x L: 91 x D: 76 x SH: 41 cm

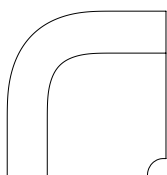

Sum modular sofa 150 corner
H: 76 x L: 86 x D: 86 x SH: 41 cm

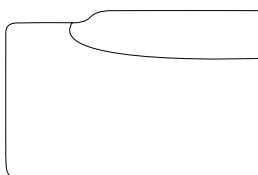

Sum modular sofa 110 center
H: 76 x L: 115 x D: 76 x SH: 41 cm

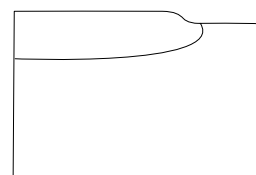

Sum modular sofa 120 right armrest
H: 76 x L: 115 x D: 76 x SH: 41 cm

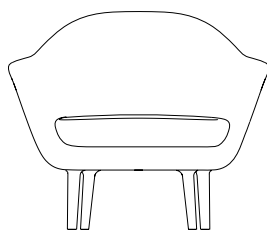

Sum Armchair
H: 76 x L: 86 x D: 86 x SH: 41 cm

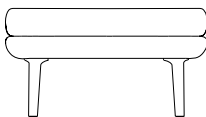

Sum modular sofa 700 pouf small
H: 41 x L: 73 x D: 73 x SH: 41 cm

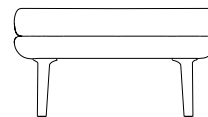

Sum modular sofa 710 pouf large
H: 41 x L: 93 x D: 73 x SH: 41 cm





Sum modular sofa

Product facts and options

Description

Sum is a light and elegant modular sofa, which can be built up from eight different modules. Add up the parts you want into a customized sofa design and create welcoming and vibrant lounge areas, supplemented by the series' matching armchair and poufs.

Designer / Year Of Design

Simon Legald / 2018

Material

Shell: PU foam with upholstery

Cushion: Soft molded PU foam with upholstery

Legs: Aluminum / Powder coated aluminum

Construction

The Sum modules are made of soft molded PU foam with a steel reinforcement structure inside. The cushion is made of cut PU foam. Textile or leather upholstery. The sofa is easily assembled and assembly manual is included

Accessories

Comes with PE glides.

Legs



Aluminum



Black aluminum

Upholstery (all available in several colors)



Camira
Synergy



Camira
Main Line Flax



Camira
Aquarius

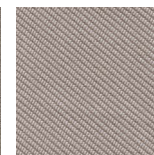

Camira
Oceanic

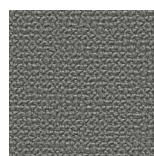

Camira
Yoredale



Camira
Zap



Sørensen Leather
Ultra



Sum armchair



Swell sofa 3 seater

Swell

Soft shapes and sublime
sitting comfort

Swell is a minimalistic furniture collection with a playful, light-hearted feel designed by the Swedish designer Jonas Wagell. The Scandinavian simplicity of the design is accentuated by a stringent design without unnecessary details. In spite of this, Swell oozes with character and personality and its soft, curved shapes make it both inviting and provide a fantastic sitting comfort. The name Swell is a reference to rising bread with its full shape, consisting of a robust padded back and seat and two curvy armrests. The stitching on the back and the seat divides the sofa into sections and completes the feel.



Swell armchair



Swell sofa

Collection

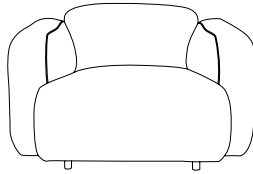

Swell armchair

H: 70 x L: 102 x D: 93 x SH: 42 cm

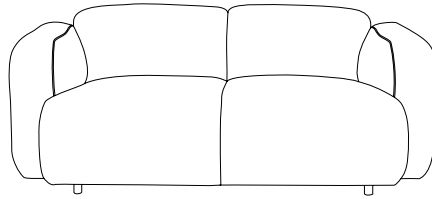

Swell sofa 2 seater

H: 70 x L: 167 x D: 93 x SH: 42 cm

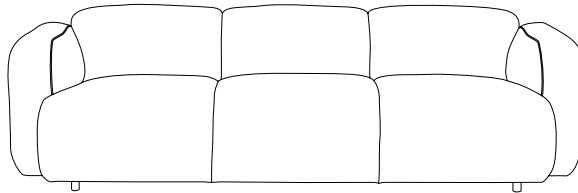

Swell sofa 3 seater

H: 70 x L: 235 x D: 93 x SH: 42 cm



Swell armchair in various textiles

Right:
Swell armchair

Below:
Swell sofa 2 seater



Product facts and options

Description

The voluminous silhouettes of the Swell series give the furniture pieces a playful and light-hearted feel and ensure a great sitting comfort. The name Swell is a reference to rising bread. The stitching on the back and the seat divides the sofa into sections and completes the look.

Designer / Year Of Design

Jonas Wagell / 2013

Material

Shell: HR foam with upholstery, plywood
Legs: Painted and lacquered ash.

Construction

Swell consists of a solid plywood frame with Nozaq springs with HR 38 cold foam on the seat and HR 35 cold foam on the back and armrests. On top is a layer of supersoft S25 cold foam which ensures optimal comfort. The legs are made of painted and lacquered ash.

Accessories

Comes with felt glides.

Legs



Black

Upholstery (all available in several colors)



Camira
Synergy



Camira
Main Line Flax

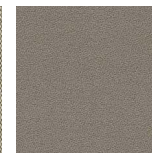

Camira
Aquarius



Camira
Oceanic

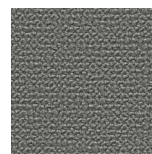

Camira
Yoredale



Camira
Zap



Pad lounge chair low steel

Pad

Comfortable and streamlined,
classic and foresighted

The Pad lounge series attains its special character from the combinations of materials, tactility and shape. Molded shells in oak veneer stand in contrast to a soft padded front while a metal frame adds strength and airiness. In full, a balanced design which captures the comfortable and the streamlined, the classic and the foresighted. The shape is boxy, yet perfectly rounded; Organic texture and warmth flirt with cool shine in the meeting of wood, textile and steel. The front-padded design is as comfortable as it is elegant, making Pad the perfect addition to the sophisticated lounge or lobby.

Collection

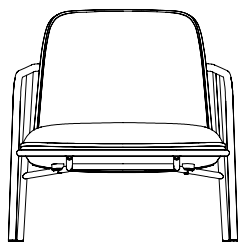

Pad lounge chair low
H: 79 x L: 77,5 x D: 78 x SH: 40,5 cm



Pad lounge chair low swivel
H: 83 x L: 82,5 x D: 82,5 x SH: 43,5 cm

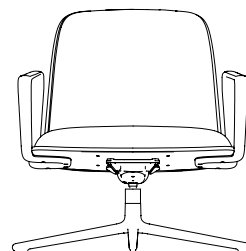

Pad lounge chair low swivel tilt
H: 83 x L: 82,5 x D: 82,5 x SH: 43,5 cm

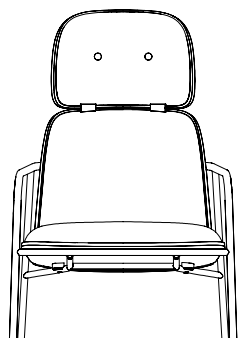

Pad lounge chair high
H: 111,5 x L: 77,5 x D: 83 x SH: 40,5 cm

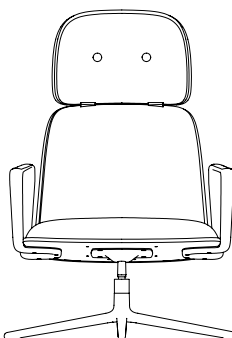

Pad lounge chair high swivel
H: 116,5 x L: 82,5 x D: 82,5 x SH: 43,5 cm

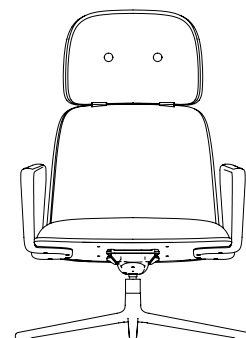

Pad lounge chair high swivel tilt
H: 116,5 x L: 82,5 x D: 82,5 x SH: 43,5 cm

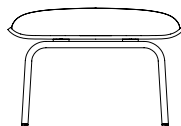

Pad footstool
H: 41 x L: 60,5 x D: 45,5 cm



Pad lounge chair high



Above:
Pad lounge chair low

Right:
Pad lounge chair low,
Pad footstool



Product facts and options

Description

Comfortable and streamlined, classic and foresighted, the multi-faceted design of the Pad lounge series is crafted from the aesthetic interplay between contrasting shapes and textures. The series comprises a high and a low lounge chair as well as a complementing footstool.

Designer / Year Of Design

Simon Legald / 2018

Material

Shell: Lacquered oak veneer or painted and lacquered ash veneer, PU foam and front upholstery, Legs: powder coated steel

Construction

Pad is made in molded oak veneer or painted and lacquered ash veneer with molded PU foam. Inside it has a steel reinforcement structure for flexibility and the highest possible sitting comfort. Textile or leather front upholstery. Legs are made of powder coated steel tubes. Pad is delivered assembled.

Accessories

Comes with PE glides. Felt glides can be purchased separately. See Glides Overview.

Test

Pad lounge chair
ANSI/BIFMA X5.4-2012

Shell

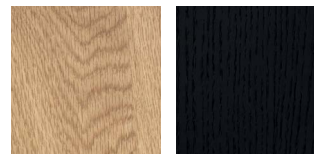

Oak

Black

Steel legs / Swivel legs



Black

Grey

Upholstery (all available in several colors)



Camira
Synergy

Camira
Main Line Flax

Camira
Aquarius

Camira
Oceanic

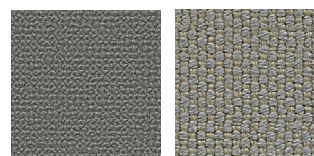

Camira
Yoredale

Camira
Zap



Sørensen Leather
Ultra



Rope modular sofa

Rope

Minimalistic and full of character

Clean and softly rounded lines give the Rope modular sofa an expression that is simultaneously minimalistic and full of character. A classic piping is highlighted as the main detail of the design, marking the edge of the sofa in an understated and fluid way. To achieve the highest levels of comfort, the Rope sofa is built with pocket springs and foam, ensuring soft and supportive seating that shapes itself according to body contours. The Rope modular sofa works well in widespread arrangements where modules and textiles mix into colorful and inspiring hang-outs.



Rope modular sofa in various textiles



Collection

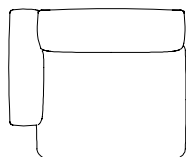

**Rope modular sofa
100 narrow left armrest**
H: 67 x L: 105 x D: 86 x SH: 39 cm

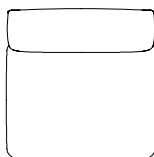

**Rope modular sofa
110 narrow center**
H: 67 x L: 86 x D: 86 x SH: 39 cm

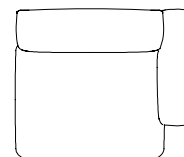

**Rope modular sofa
120 narrow right armrest**
H: 67 x L: 105 x D: 86 x SH: 39 cm

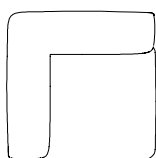

**Rope modular sofa
150 narrow corner**
H: 67 x L: 86 x D: 86 x SH: 39 cm

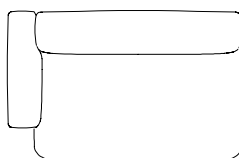

**Rope modular sofa
300 wide left armrest**
H: 67 x L: 138 x D: 86 x SH: 39 cm

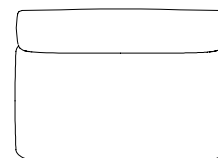

**Rope modular sofa
310 wide center**
H: 67 x L: 120 x D: 86 x SH: 39 cm

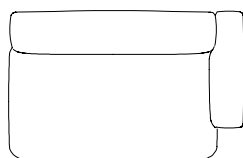

**Rope modular sofa
320 wide right armrest**
H: 67 x L: 138 x D: 86 x SH: 39 cm

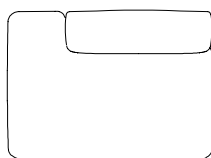

**Rope modular sofa
330 wide open left side**
H: 67 x L: 120 x D: 86 x SH: 39 cm

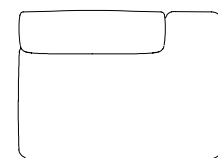

**Rope modular sofa
340 wide open right side**
H: 67 x L: 120 x D: 86 x SH: 39 cm

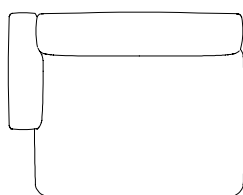

**Rope modular sofa
400 wide chaise longue left armrest**
H: 67 x L: 138 x D: 120 x SH: 39 cm

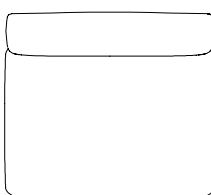

**Rope modular sofa
410 wide chaise longue center**
H: 67 x L: 120 x D: 120 x SH: 39 cm

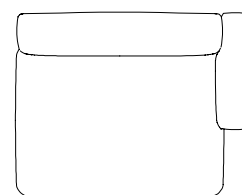

**Rope modular sofa
420 wide chaise longue right armrest**
H: 67 x L: 138 x D: 120 x SH: 39 cm



Rope modular sofa 700 pouf small
H: 39 x L: 86 x D: 67 cm

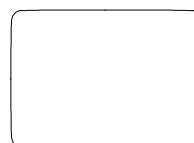

Rope modular sofa 710 pouf large
H: 39 x L: 120 x D: 86 cm



Rope modular sofa



Rope modular sofa

Product facts and options

Description

Rope emphasizes flexibility and comfort in a modular design that offers a wealth of opportunities for personal style. The design plays with curves and dimensions in order to give Rope an expression that is simultaneously minimalistic and full of character. A clean and simple piping is highlighted as the main detail of the design.

Designer / Year Of Design

Hans Hornemann / 2016

Material

Shell: HR foam with pocket springs and upholstery

Legs: Painted and lacquered ash

Construction

Rope sofa consists of a wooden frame with pocket springs.

The frame is covered in durable furniture foam all over, ensuring optimal sitting comfort. The sofa features piping on all edges.

The legs are made of black lacquered wood and measure approx. 1,5 cm in height.

Accessories

Comes with felt glides.

Upholstery



Camira
Synergy



Camira
Main Line Flax

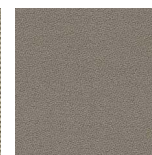

Camira
Aquarius



Camira
Oceanic

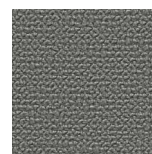

Camira
Yoredale



Camira
Zap

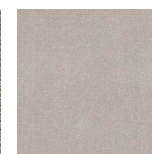

JAB
City Velvet



Sørensen Leather
Optimo



Poufs & stools

Decorative and convenient, we love poufs and stools for providing chic casual seating and footrest whenever needed. Scatter them in groups over a larger lounge area or place them individually in a dressing room, hotel room or hallway. No matter the setting, the easy extra seat is always joyously welcomed.



Tap stool walnut

Tap

An unexpected yet familiar stackable stool

The rethinking of something as simple as a stool was the starting point for Normann Copenhagen's Tap stool. The designer Simon Legald has taken up the challenge and breathed new life into the traditional stool with original materials and details. In doing so, he has created a practical and beautiful design in the cross field of craftsmanship and industry. Tap is an unexpected, different, yet familiar stackable stool in a class of its own. The molded seat ensures good seating comfort and provides the stool with the same welcoming warmth known from upholstered furniture. The three legs have an integrated transition to the seat. This gives Tap the appearance of a unified whole, even when seen from the side.

Tap stool oak



Product facts and options

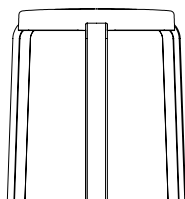

Tap stool

H: 43 x L: 41 x Ø: 35 cm

Description

Tap is a different yet familiar stackable stool. The stool surprises you with its unexpectedly comfortable seat made from molded foam with a flexible, sealed surface. The three legs are smoothly integrated into the seat. This gives Tap the appearance of a unified whole even when seen from the side.

Designer / Year Of Design

Simon Legald / 2014

Material

Seat: PU foam

Legs: Oak veneer / Walnut veneer / Painted and lacquered oak

Construction

The seat of the Tap stool is made of a hard PU foam with a closed cell structure for durability and easy maintenance. The Tap stool comes flat-packed. Assembly manual included.

Maintenance

Clean with a damp cloth.

We recommend to check and tighten screws every 3-6 months.

Please be aware that sharp edges can leave marks on the soft foam.

Test

EN 1022:2005 and EN 16139:2013. Level 2

Legs

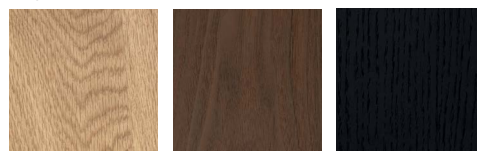

Oak

Walnut

Black
(only available with
black seat)

Seat



Black

Grey

Olive

Sand



Caramel



Tap stool oak,
Tap stool walnut,
Tap stool black

Tap stool oak,
Tap stool walnut,
Tap stool black





Circus pouf small and large

Circus

Playful and sophisticated seating

Circus is a pouf that has an exclusive, Scandinavian feel, created by the Danish designer, Simon Legald. The pouf is rounded in shape, with the clean, graphic lines characteristic of Scandinavian design. The versatile Circus pouf allows contradictions to meet in a design whose style is strict and minimalist, while at the same time having a soft and inviting expression. Circus draws inspiration from antique Moroccan leather poufs, whose focus is on handcraft, and it explores the design construction and plays with the details. The traditional patchwork patterns are replaced by a plain triangle motif, giving the pouf a contemporary look. Circus is a playful, yet at the same time sophisticated, addition to any furnishing.

Product facts and options

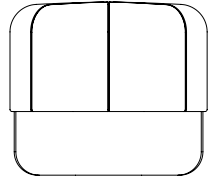

Circus pouf small
H: 40 x L: 46 x D: 46 cm

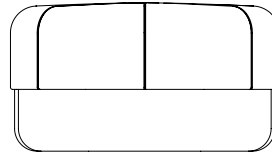

Circus pouf large
H: 35 x L: 65 x D: 65 cm

Description

With its rounded shape and clean, graphic lines the Circus pouf is a modern interpretation of the antique Moroccan leather pouf. The pouf allows contradictions to meet in a design which style is stringent and minimalist, while keeping a soft and inviting expression.

Designer / Year Of Design

Simon Legald / 2013

Material

HR foam with upholstery

Construction

Circus consists of hard foam in the bottom part and a softer foam on the upper part for good sitting comfort. The pouf is covered in velvet that is sewn together. The pouf has a wooden plate at the bottom for stability.

Upholstery



JAB City Velvet
Beige
CA7832-096



JAB City Velvet
Yellow
CA7832-060



JAB City Velvet
Grey
CA7832-093

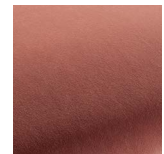

JAB City Velvet
Blush
CA7832-069

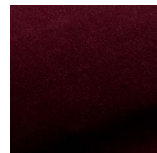

JAB City Velvet
Dark red
CA7832-081

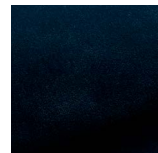

JAB City Velvet
Dark blue
CA7832-052

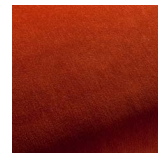

JAB City Velvet
Rust
CA7832-062

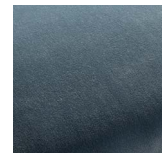

JAB City Velvet
Light blue
CA7832-062

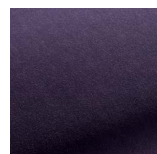

JAB City Velvet
Purple
CA7832-062



JAB City Velvet
Electric blue
CA7832-053

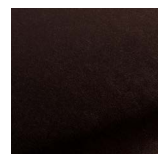

JAB City Velvet
Coffee
CA7832-024

Circus pouf small





Silo pouf small

Silo

Geometric silhouette in vibrant upholstery

The Silo pouf takes its name from its simple cylindrical shape, which forms a strict contrast to the vibrant upholstery. Luxurious, woven textiles from the Italian manufacturer Imatex give the pouf a stroke of extravagance that is held neatly in place by the simple geometric silhouette. Silo has a soft but firm surface so that it can act as a stand-in for a coffee table, for example to keep magazines and literature. The pouf can live in a hall, living room, dressing room or bedroom as a flexible and decorative addition to the furnishings.

Product facts and options

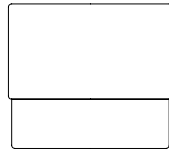

Silo pouf small
H: 46 x Ø: 50 cm

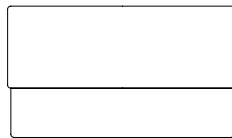

Silo pouf medium
H: 43 x Ø: 70 cm

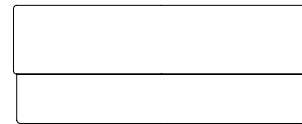

Silo pouf large
H: 39 x Ø: 90 cm

Description

The Silo pouf takes its name from its simple cylindrical shape, which forms a strict contrast to its vibrant upholstery. Silo has a soft but firm surface so that it can act as a stand-in for a coffee table. The pouf can live in a hall, a living room, a dressing room or in a bedroom as a flexible and decorative addition to the furnishing.

Designer / Year Of Design

Hans Hornemann / 2017

Material

Plywood / PU foam with upholstery

Construction

Silo pouf is made of cut PU foam glued to plywood boards. The plywood creates stability in the construction while adding a sharp visual profile. The foam creates soft comfort with a firm surface.

Upholstery

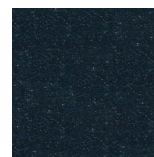

Imatex Bolgheri
8 Deep sea



Imatex Bolgheri
7 Earth confetti

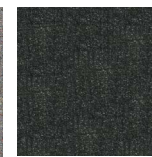

Imatex Bolgheri
4 Coffee grounds

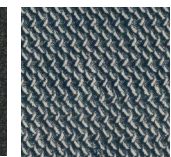

Imatex Albagia
288 Navy blue

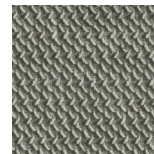

Imatex Albagia
214 Dusty brown

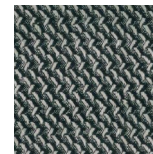

Imatex Albagia
201 Black



Imatex Wynwood
8 Riviera blue

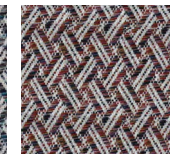

Imatex Wynwood
13 Carnival red

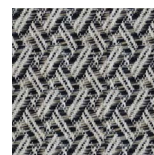

Imatex Wynwood
10 Piazza grey



Silo pouf in various combinations



Tables

Life is lived at the table. Whether it's enjoying a good meal in the company of friends or during long hours of work, we spend a great deal of time around tables. Our tables are made with durable materials and maintenance-friendly surfaces to make them fit for daily wear and tear.



Union bar table 190 x 60 x H95,5 cm

Union

A versatile table collection

A place for meals, work, studying, conversations and relaxation; a table is a base and gathering place for all sorts of activities, and the Union series accommodates them all. Union is a timeless table series in a minimalistic, monochrome design with subtle brass details. The tabletop is made from premium nano-coated laminate, while an airy steel design makes up the base. Encompassing fifteen tables of varying shapes, heights and sizes, the series offers a broad range of furnishing options for both private and public spaces.





Union table in various sizes

Collection

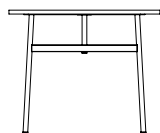

Union table 90 x 90 cm
H: 74 x L: 90 x D: 90 cm

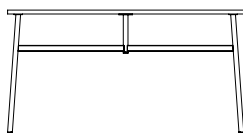

Union table 140 x 90 cm
H: 74 x L: 140 x D: 90 cm

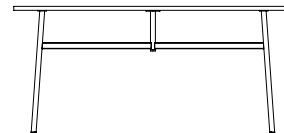

Union table 160 x 90 cm
H: 74 x L: 160 x D: 90 cm

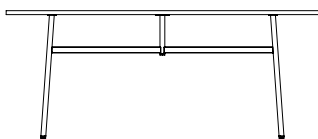

Union table 180 x 90 cm
H: 74 x L: 180 x D: 90 cm

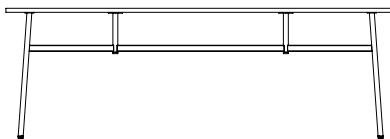

Union table 220 x 90 cm
H: 74 x L: 220 x D: 90 cm

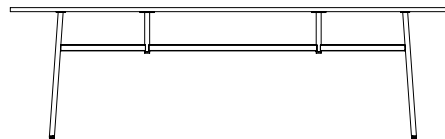

Union table 250 x 90 cm
H: 74 x L: 250 x D: 90 cm

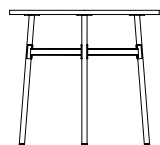

Union table Ø80 x H74,5 cm
H: 74,5 x Ø: 80 cm

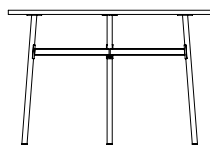

Union table Ø110 x H74,5 cm
H: 74,5 x Ø: 110 cm

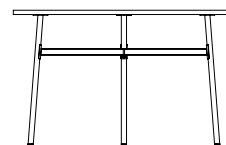

Union table Ø120 x H74,5 cm
H: 74,5 x Ø: 120 cm

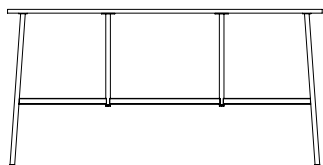

Union bar table 190 x 60 cm x H95,5
H: 95,5 x L: 190 x D: 60 cm

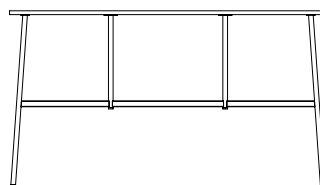

Union bar table 190 x 60 cm x H105,5
H: 105,5 x L: 190 x D: 60 cm

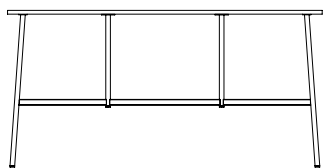

Union bar table 190 x 90 cm x H95,5 cm
H: 95,5 x L: 190 x D: 90 cm

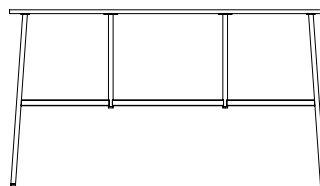

Union bar table 190 x 90 cm x H105,5 cm
H: 105,5 x L: 190 x D: 90 cm

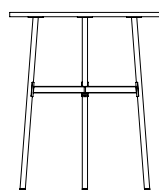

Union table Ø80 x H95,5 cm
H: 95,5 x Ø: 80 cm

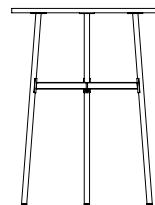

Union table Ø80 x H105,5 cm
H: 105,5 x Ø: 80 cm



Union table 140 x 90 cm



Union table Ø80 x H95,5 cm

Product facts and options

Description

Union is an all-round collection of tables in a minimalistic, monochrome design, which gets an elegant lift from shiny brass feet. With everything from dining tables to tall café tables, the collection offers a broad range of furnishing options for both private and public spaces.

Designer / Year Of Design

Simon Legald / 2018

Material

Tabletop: "Arpa Fenix" high-pressure laminate on particle board
Legs: Powder coated steel

Construction

The tabletop is made of particle board with premium nano-coated laminate for a fingerprint-free surface with higher scratch resistance. Legs are made of powder coated steel with brass fittings. Union comes flat-packed and is easily assembled. Assembly manual included.

Accessories

Compatible with our chair suspension.

Color



White

Grey

Black



Union bar table 190 x 60 cm x H105,5 cm



Form café table marbre Ø70 x H74,5 cm

Form café table

Clean and contemporary café tables

Timeless café tables with a centered steel base and wood, linoleum or marble tabletops complete the Form series' versatile table selection. The tables are adjusted to the Form chair and the two heights of Form barstools so that they complement each other proportionally. The Form café table is particularly well suited to the decor of bars, restaurants, lobbies and receptions, but will also work perfectly in a kitchen's little eating area in private homes.





Form café table wood 70 x 70 x H74,5 cm with various tabletops

Collection

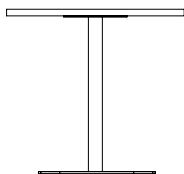

Form café table 70 x 70 x H65 cm
H: 65 x L: 70 x D: 70 cm

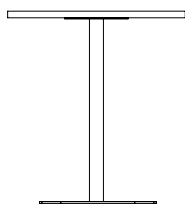

Form café table 70 x 70 x H74,5 cm
H: 74,5 x L: 70 x D: 70 cm

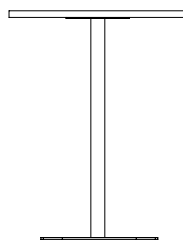

Form café table 70 x 70 x H94,5 cm
H: 94,5 x L: 70 x D: 70 cm

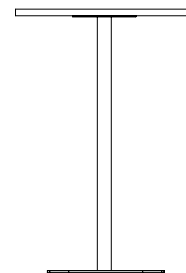

Form café table 70 x 70 x H104,5 cm
H: 104,5 x L: 70 x D: 70 cm

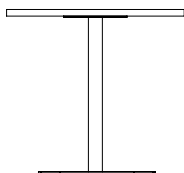

Form café table Ø70 x H65 cm
H: 65 Ø: 70 cm

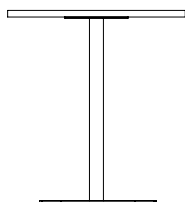

Form café table Ø70 x H74,5 cm
H: 74,5 Ø: 70 cm

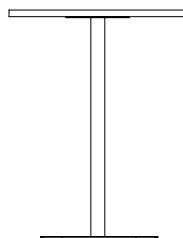

Form café table Ø70 x H94,5 cm
H: 94,5 Ø: 70 cm

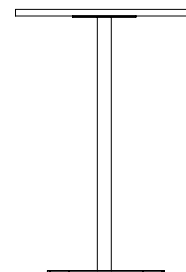

Form café table Ø70 x H104,5 cm
H: 104,5 Ø: 70 cm

Form café table marbre 70 x 70 x H94,5 cm,
Form café table marbre Ø70 x H104,5 cm,
Form café table marbre Ø70 x H74,5 cm





Form café table wood Ø70 x H74,5 cm



Form café table marbre Ø70 x H74,5 cm



Form café table marble Ø70 x H65 cm

Product facts and options

Description

Timeless café tables with a centered steel base and wood or marble tabletops complete the Form series' versatile table selection.

Designer / Year Of Design

Simon Legald / 2018

Material

Tabletop: Lacquered oak veneer / Painted & lacquered oak veneer / Marble

Legs: Powder coated steel

Construction

The table comes flat packed. Easily assembled by following the manual included.

Metal base



Black

Tabletop wood

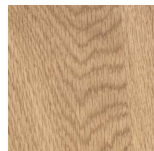

Oak

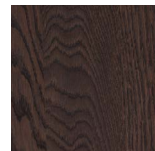

Smoked oak

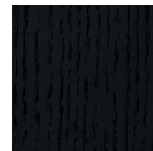

Black oak

Tabletop marble



White
(White carrara)

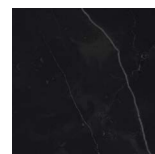

Black
(Black pearl)

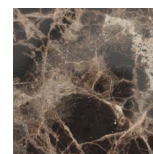

Coffee
(Dark emperor)

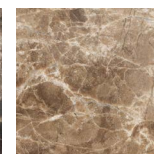

Sand
(Light emperor)



Slice table 84 x 160 cm linoleum

Slice

Scandinavian design
in high-quality materials

Made of natural, high-quality materials that exude warmth and exclusiveness, the Slice series is an invitation to a world of enjoyable get-togethers. Great attention has been paid to the details in order to create a completely aesthetic design that is both timeless and harmonic. The natural interaction is emphasized in the rustic tabletop, where each plank accentuates the grain of the wood and its texture and brings the design alive. The durability of the materials makes Slice suitable for homes, offices and restaurants that need a design that can withstand both frequent and long-term use.



Slice table vol. 2 Ø200 cm oak



Collection

Slice table



Slice table 90 x 200 cm
H: 74 x L: 200 x D: 90 cm



Slice table 90 x 250 cm
H: 74 x L: 250 x D: 90 cm



Slice table 90 x 300 cm
H: 74 x L: 300 x D: 90 cm

Slice table vol 2



Slice table vol. 2 84 x 160 cm
H: 74 x L: 160 x D: 84 cm



Slice bar table vol. 2 90 x 200 cm
H: 103 x L: 200 x D: 90 cm



Slice coffee table vol. 2 42 x 100 cm
H: 39 x L: 100 x D: 42 cm

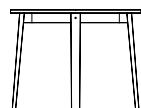

Slice table vol. 2 Ø95 cm
H: 74 x Ø: 95 cm

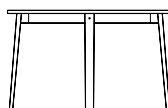

Slice table vol. 2 Ø120 cm
H: 74 x Ø: 120 cm

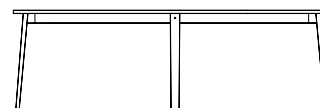

Slice table vol. 2 Ø200 cm
H: 74 x Ø: 200 cm



Slice bench vol. 2 38 x 160 cm
H: 42 x L: 160 x D: 38 cm

Slice table linoleum



Slice table 90 x 200 cm linoleum
H: 74 x L: 200 x D: 90 cm



Slice table 90 x 250 cm linoleum
H: 74 x L: 250 x D: 90 cm



Slice table 90 x 300 cm linoleum
H: 74 x L: 300 x D: 90 cm



Slice table 84 x 160 cm linoleum
H: 74 x L: 160 x D: 84 cm



Slice bar table 90 x 200 cm linoleum
H: 103 x L: 200 x D: 90 cm

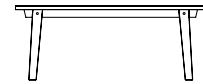

Slice coffee table 42 x 100 cm linoleum
H: 39 x L: 100 x D: 42 cm

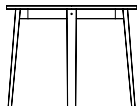

Slice table Ø95 cm linoleum
H: 74 x Ø: 95 cm

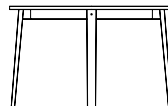

Slice table Ø120 cm linoleum
H: 74 x Ø: 120 cm

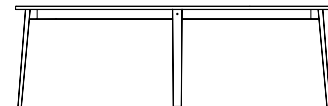

Slice table Ø200 cm linoleum
H: 74 x Ø: 200 cm



Slice bench 38 x 160 cm linoleum
H: 42 x L: 160 x D: 38 cm



Above:
Slice bench vol. 2 38 x 160 cm oak

Right:
Slice table 90 x 200 cm oak



Slice table 90 x 250 cm linoleum





Slice table Ø120 cm linoleum

Product facts and options

Description

Slice is a classic table in oak veneer with an exquisite finish that fits beautifully with a Scandinavian decor. The hardness and durability of the materials make the table suited for frequent and long-term use.

Designer / Year Of Design

Hans Hornemann / 2014

Material

Tabletop: Lacquered oak veneer / Linoleum with oak veneer edges
Legs: Lacquered oak

Construction

The tabletop (3 cm thick) consists of oak veneer supported by a wooden cross rail and a solid oak frame with legs. The table comes flat-packed. Assembly manual included.

Frame

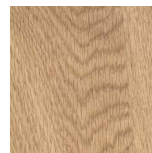

Oak

Tabletop



Oak

Linoleum / Oak edges
(Linoleum available in several colors)



Journal desk white

Journal

Functional down to
the smallest detail

Journal is functional down to the smallest detail and has an inviting appearance, which makes it a stylish addition to any modern decor. Designer Simon Legald has created a table with a thoroughly stylish design that can join as a harmonious and aesthetically relevant part of the home's decor. The simple frame is inspired by old French industrial furniture and is constructed from a combination of tubular steel and sheet steel with slightly outward sloping legs. The frame and the laminate desktop are colored in the same subdued shades. In the design of Journal, practical usage is addressed by discrete, functional details to create a pleasant environment in which good ideas can flow freely.

Collection

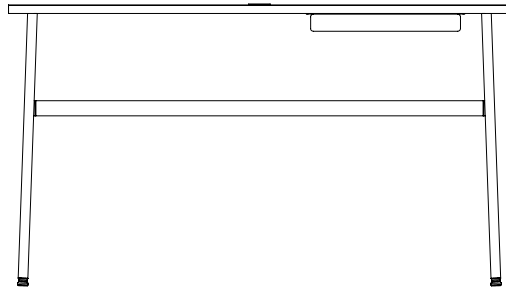

Journal desk
H: 74 x L: 130 x D: 65 cm



Journal desk grey



Journal desk black

Product facts and options

Description

A colored desktop flirts with a light steel frame in the design of the Journal desk, while practical usage is addressed by discrete functional details. The desktop has an integrated wire grommet. A steel drawer under the desktop provides space for office supplies.

Designer / Year Of Design

Simon Legald / 2016

Material

Tabletop: Laminate
Legs: Powder coated steel
Drawer: Powder coated steel

Construction

Laminated tabletop with oak edge, powder coated steel legs and steel drawer, painted in same color as tabletop and legs. Silicone wire grommet for power cords.

Steel legs



White

Grey

Black

Tabletop



White

Grey

Black



Side & coffee tables

For the display of beautiful books and magazines, the pedestal presentation of flower arrangements and table lamps, or quite simply a place to put down a cup of coffee, the usages of small tables are almost as manifold as their appearances.



Ding table smoke / black

Ding

A sculptural coffee table

Inspired by ancient three-dimensional wooden brain teaser puzzles, the German design duo Rudolph Schelling Webermann have created a simple coffee table that is assembled without the help of screws and tools. The table consists quite simply of three legs made from oak. When put together they constitute a sculptural knot that works as the base for an exclusive glass tabletop.

Product facts and options

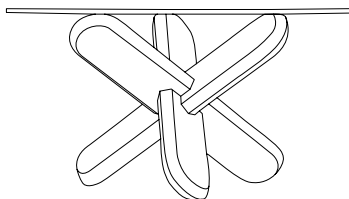

Ding table
H: 40 x Ø: 70 cm

Description

The Ding table consists quite simply of three legs made from oak that are assembled without screws and tools. When put together they constitute a sculptural knot that works as the base for an exclusive glass tabletop.

Designer / Year Of Design

Rudolph Schelling Webermann / 2013

Material

Tabletop: Glass

Legs: Lacquered oak / Painted and lacquered oak

Construction

The Ding table comes flat-packed. The legs interlock easily by following the included manual. The legs have chamfered edges making the table stand sturdily on the floor and the round 12 mm thick sheet of glass rest solidly on the base.

Base

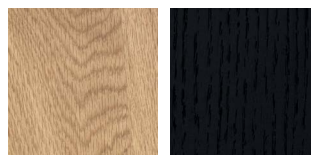

Oak

Black

Glass tabletop



Clear

Smoke



Ding table clear / oak



Tablo table small

Tablo

Function and aesthetic united
in a simple design

Nicholai Wiig Hansen has created a table which unites function and aesthetics in a simple design. The refinement of the tabletop's sharpened edge complements the lacquered legs beautifully and gives the table a pure and minimalistic feel. The name, Tablo, refers to the English 'table' and the French 'tableau', the latter meaning a scenic, organized arrangement. With its simple expression, Tablo fits into most interior styles and is available in a small and large version.

Product facts and options

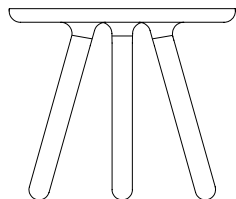

Tablo table small
H: 42 x Ø: 50 cm

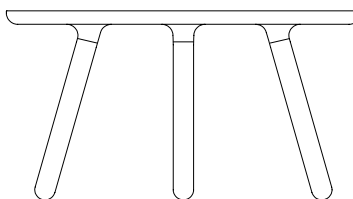

Tablo table large
H: 42 x Ø: 78 cm

Description

The Tablo table unites function and aesthetics in a simple design that fits into most interior styles. The refinement of the tabletop's sharpened edge complements the lacquered legs beautifully and gives the table a pure and minimalistic feel.

Designer / Year Of Design

Nicholai Wiig Hansen / 2011

Material

Tabletop: Plastic composite
Legs: Lacquered ash

Construction

The Tablo table comes flat packed. The table is quickly and easily assembled without the use of any tools and screws.

Legs

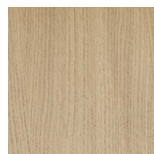

Ash

Tabletop



White

Grey

Black



Tablo table large

Stock table



Stock

Architectural little side table

Using the most elementary steel stock parts as their starting point, MSDS Studio has created an architectural little side table. Their design 'Stock' presents metal in a raw and deconstructed way, while retaining a delicate, rigid quality. The table's unconventional leg arrangement emphasizes the material's strength and produces an interesting composition of elements. The aesthetic negative spaces – the airy open area under the tabletop and the triangle between the angled legs – come from disregarding the traditional arrangement of table legs, creating a new form of symmetry. Stock appears as a small, strict piece of sculpture, which also serves as a practical, stable side table.



Product facts and options

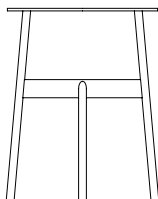

Stock table

H: 46 x D: 37,5 x Ø: 37 cm

Description

Stock is an architectural little side table, made using the most elementary steel stock parts. The design presents metal in a raw and deconstructed way while retaining a delicate, rigid quality. Stock's unconventional leg arrangement emphasizes the material's strength and produces an interesting composition of elements.

Designer / Year Of Design

MSDS Studio / 2018

Material

Powder coated steel

Construction

Stock is delivered assembled.

Colors

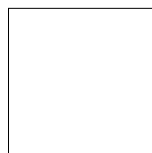

White



Wine



Steel blue



Black

Turn table



Turn

Height adjustable coffee table
for a multitude of settings

The Turn table is a small yet functional table in wood and steel. The name Turn refers to the rotational movement used to adjust the height of its round tabletop, gently raising it up from its bell-shaped steel base. With a minimum height of 41.5 cm and a maximum height of 66.5 cm, this small table can be easily adjusted to suits its existing surroundings.

Product facts and options

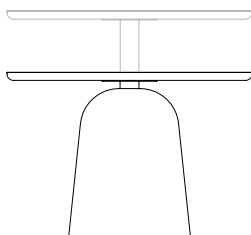

Turn table

H: 41.5 - 64 x Ø: 55 cm

Description

Well-suited for use as a coffee or side table, the Turn table can easily be adjusted to its surroundings by turning the tabletop, which raises or lowers the table.

Designer / Year Of Design

Simon Legald / 2020

Material

Powder coated steel and painted and lacquered ash veneer

Dimensions

H: 41,5-64 cm x Ø: 55 cm

Construction

A spun steel base with metal tubes supports a pressed steel top with embedded veneer board. The ash veneer tabletop is lacquered in the same color as the steel base.

Color

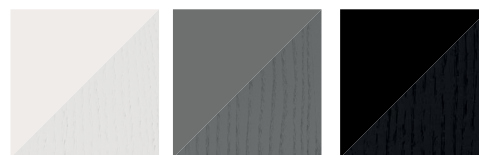

Warm grey

Grey

Black



Turn table

Lug table small,
Lug table large



Lug

Balancing feminine elegance and industrial mechanics

The steel parts of vintage bicycles have provided inspiration for the design of the Lug table's simple steel frame. Its slender, slightly curved table legs emulate the front fork of a bicycle, almost giving the impression of a table in motion. The frame is joined by a prominent brass piece which highlights the honesty of its construction and contrasts nicely with the otherwise monochrome table. The name Lug refers to this particular kind of joint – a component that is very well known within the world of cycling and which often adds an esthetic touch to older models. The larger Lug table makes for an obvious companion piece to sofas in a lounge area, while the smaller table is suitable as a side table or bedside table.

Product facts and options

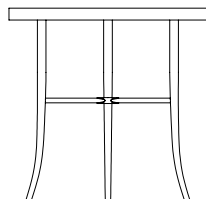

Lug table small
H: 49 x Ø: 50 cm

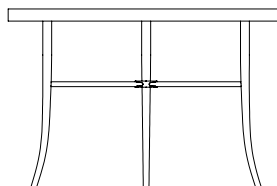

Lug table large
H: 44,5 x Ø: 68 cm

Description

Light on its feet, the Lug table is a balance of feminine elegance and industrial mechanics. The design consists of two smaller tables in steel with glass tabletops in the same shade.

Designer / Year Of Design

Simon Legald / 2020

Material

Top: Glass

Legs: Powder coated steel

Construction

The powder coated steel frame is connected with a brass plated steel connector detail. The colored glass tabletop rests on the steel base and is framed by a steel edge. The table comes flat-packed with 6 parts and 12 screws with tools included.

Color



Grey

Black

Lug table small



Solid table



Solid

Japanese architecture meets Scandinavian craftsmanship

Solid is a minimalist coffee table made from natural, solid materials that unite Scandinavian craftsmanship with the basic principles of Japanese architecture. The result is a timeless and sturdy coffee table with a simple design stripped of unnecessary details. The designer, Lars Beller Fjetland, has based Solid's design on a more than 1,000 year old Japanese structure called Torii. Torii was originally the entrances to Shinto temples, which were used for worship and storage of sacred objects. The reference is evident in the choice of materials that are in tune with the original wood and stone used for the Torii gates, but with a Scandinavian twist.

Product facts and options



Solid table

H: 40 x L: 130 x D: 38,5 cm

Description

Solid is a minimalistic coffee table made from natural, solid materials that unite Scandinavian craftsmanship with the basic principles of Japanese architecture. The result is a timeless and sturdy coffee or side table with a simple design stripped of unnecessary details.

Designer / Year Of Design

Lars Beller Fjetland / 2013

Material

Tabletop: Marble

Legs: Lacquered ash

Construction

The Solid table comes flat-packed. It is simple and intuitive to assemble without the use of any screws or tools. The parts lock together under the weight of the 25 mm thick tabletop, forming a sturdy construction.

Color



Ash / White marble



Solid table



Pine table small

Pine

Sculptural design
shines light on pinewood

There is something both earthily Nordic and expressively avant-garde about the collection of small tables that go by the name Pine. The tables are made from solid pine in a characterful and sculptural design. The choice of pinewood sets the tone for the design of the Pine tables. The tables gain a pleasing organic quality from the wood's distinctive grain, and the overlooked wood species is given new life in a playful form. With its voluminous octangular foot, Pine can lend prominence and vigor to any room.

Product facts and options

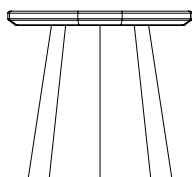

Pine table small
H: 40,6 x Ø: 45 cm

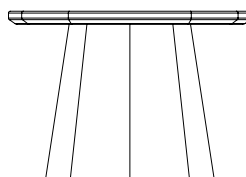

Pine table large
H: 44,6 x Ø: 65 cm

Description

Pine is a series of small tables in pinewood. The combination of the voluminous octagonal foot and the light tabletop makes a characteristic, sculptural design. Use the larger version as a coffee table or combine it with the smaller table, elegantly tucked in underneath.

Designer / Year Of Design

Simon Legald / 2018

Material

Stained lacquered pine

Construction

Pine table is made of solid pine planks. The table is delivered assembled.

Color

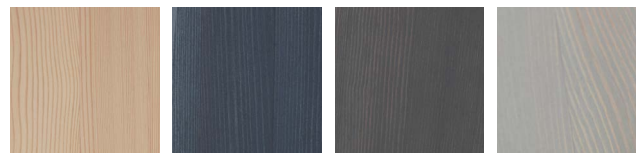

Pine

Dark blue

Dark grey

Light grey



Pine table large



Stay table 40 x 40 cm

Stay

Versatile side tables with
an industrial yet organic look

Different kinds of decor require different types of tables. This is why we have introduced Stay, a range of small, multifunctional tables in two sizes, easy to use in your home in numerous different ways. The leaves, stones and plants of nature itself inspired the shape of Stay. The round and soft shapes of the table are a fine contrast to the flat and hard steel, giving Stay both an organic and industrial look. The practical, built-in shelf is perfect for storing magazines, books, design objects or toys. You can use Stay as a coffee table, a bedside table or as a little sideboard in the office.

Product facts and options

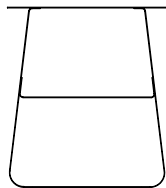

Stay table 40 x 40 cm
H: 45 x L: 40 x D: 40 cm

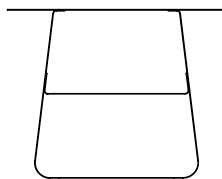

Stay table 40 x 52 cm
H: 40 x L: 52 x D: 40 cm

Description

Stay is a range of small tables in two sizes, easy to use in the interior in numerous different ways. The round and soft shapes of the table are a fine contrast to the flat and hard steel, giving Stay both an organic and industrial look. The practical, built-in shelf is perfect for storage.

Designer / Year Of Design

Jonas Wagell / 2014

Material

Powder coated steel

Construction

Stay table is made from bended steel plate. Load capacity: Approx. 20 kg. The table is delivered assembled.

Color



Stone grey

Rust

Black brown



Stay table 40 x 40 cm,
Stay table 40 x 52 cm

Grow table 50 x 60 cm oak,
Grow table 80 x 80 cm oak



Grow

Oak wood takes center stage

The Grow coffee table is made of solid oak in a finely balanced design with references to classic Danish shaker style. The table is named for the smooth transition between the tabletop and legs, which gives the impression that the legs are growing out of the tabletop. With its simple silhouette and shapely details, Grow alludes to the luxury of simplicity. The tabletop's chamfered edges and the oval legs lend the table a visual lightness, allowing the gorgeous oak wood to take center stage. Grow is a versatile design with timeless class.

Product facts and options

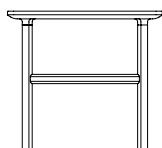

Grow table 50 x 60 cm
H: 45 x L: 50 x D: 60 cm



Grow table 80 x 80 cm
H: 35 x L: 80 x D: 80 cm



Grow table 70 x 120 cm
H: 40 x L: 120 x D: 70 cm

Description

The Grow coffee table is named for the smooth transition between the tabletop and legs, which gives the impression that the legs are growing out of the tabletop. With its simple silhouette and shapely details, Grow alludes to the luxury of simplicity. The tabletop's chamfered edges and the oval legs lend the table a visual lightness, allowing the gorgeous oak to take center stage

Color

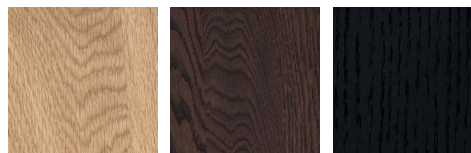

Oak

Smoked oak

Black

Designer / Year Of Design

Simon Legald / 2017

Material

Lacquered oak or painted and lacquered oak

Construction

Grow table is delivered assembled.



Grow table 70 x 120 cm black



Block table Ø45 cm,
Block table

Block

Spaciousness on a small scale

Since 2012, the best-selling and versatile mobile side table, Block, has been headed at great speed towards the title of a modern design classic. Block is a functional and charming design that can work anywhere in your home. Designer Simon Legald was inspired by the classic trolley table which he has updated and made his own with simple, yet impactful means. Block's rounded shape, contrasting materials and the combination of craft and industry leaves the designer's signature on the design and gives the series its unique expression.

Product facts and options

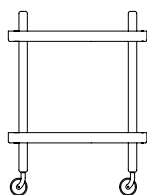

Block table
H: 64 x L: 50 x D: 35 cm

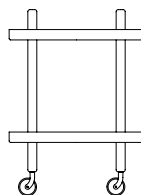

Block table Ø45 cm
H: 64 x Ø: 45 cm

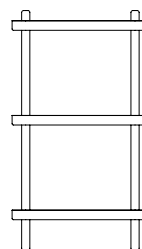

Block shelf
H: 87 x L: 50 x D: 35 cm

Description

Block's rounded shape, contrasting materials and the combination of craft and industry give the table its unique expression. The functional and charming design can work anywhere in the interior.

Designer / Year Of Design

Simon Legald / 2012

Material

Tabletop: Powder coated steel

Legs: Lacquered ash or painted and lacquered ash

Construction

The Block table and Block shelf comes flat packed. The wheels on the Block table are colored to match the trays and can be turned 360 degrees. A black nylon ring around the wheel adds grip and stability. The table is easy to move around using its handles. The Block shelf consists of three spacious tray shelves held up by a light yet solid wooden frame. Assembly manual included for both table and shelving unit. Load capacity: 10 kg per shelf.

Color

Block table



Ash / White

Ash / Grey

Ash / Dark grey

Ash / Black

Block shelf



White

Black



Block shelf



Storage

Clever storage provides the basis for a stress-free environment and plays its part in shaping a canvas that brings out our creative abilities.

With that in mind, we offer smart and contemporary storage solutions with a hint of playfulness.

Jam bookcase 6 poles



Jam

Composed of just three
different elements

Composed of just three different elements, the Jam bookcase is a cleverly and elegantly executed design. The defining element is a wedge, which allows the bookcase to be assembled without the use of screws or tools. The shelves are quite simply jammed onto the wedges and then gravity and friction take care of the rest. The shelves' softly rounded corners give the unit an inviting and friendly visual expression. With its versatile design, the bookcase works just as well in small apartments as it does in large offices, where its purity and materiality craft a calming and pleasant presence.

Product facts and options

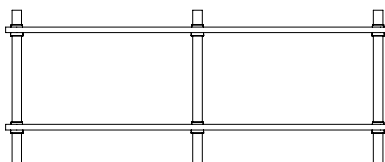

Jam bookcase 6 poles
H: 55 x L: 138 x D: 38 cm

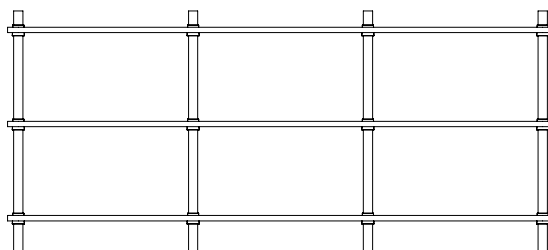

Jam bookcase 8 poles
H: 90 x L: 203 x D: 38 cm

Description

The Jam bookcase has a clever design composed of just three different elements. Using the friction of a specially designed wedge, the bookcase can be assembled without the use of screws or tools. Softly rounded corners unify the visual expression and give the bookcase a friendly appearance.

Designer / Year Of Design

Rudolph Schelling Webermann / 2018

Material

Poles: Solid lacquered oak
Shelves: MDF with oak veneer
Wedges: Polypropylene

Construction

Jam bookcase consists of poles in solid oak, shelves in chipboard with oak veneer and wedges in polypropylene. Jam bookcase is delivered with grey wedges and comes flat-packed. Assembly manual included.

Poles and shelves

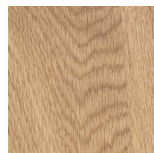

Oak

Wedges



Grey



Jam bookcase 8 poles

Kabino dresser w. 5 drawers



Kabino

Functional storage in a sensible design

Designer Simon Legald has put storage in the hot seat with a series of furniture that solves most storage needs. The **Kabino** series consists of two different sideboards, a bedside table and two dressers with five and six drawers respectively. The many small details of the designs help create a visual break in the uniform surface of the front and add dynamics. A frame of ash softens the industrial expression and adds warmth and exclusivity. The signature open handles in doors and drawers give an integrated look. All the drawers have a soft close function, which means that they close silently.

Collection

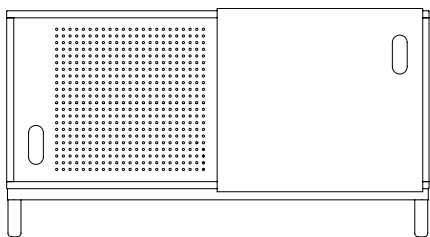

Kabino sideboard
H: 61 x L: 114 x D: 42 cm

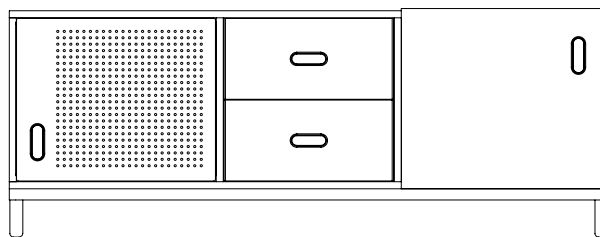

Kabino sideboard w. drawers
H: 61 x L: 161,8 x D: 41 cm

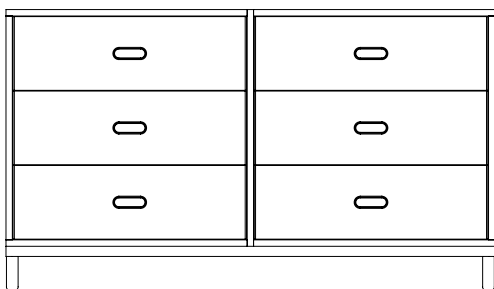

Kabino dresser w. 6 drawers
H: 83 x L: 146,5 x D: 41 cm

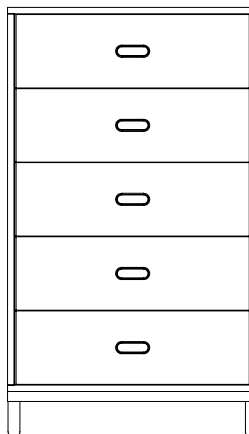

Kabino dresser w. 5 drawers
H: 127 x L: 74,2 x D: 41 cm

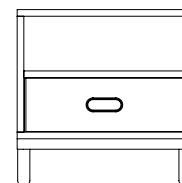

Kabino bedside table
H: 50 x L: 50 x D: 41 cm



Kabino sideboard



Kabino bedside table

Product facts and options

Description

Kabino is a series of versatile and functional furniture pieces for storage. The many small details of the designs help create a visual break in the uniform surface of the front and add dynamics. All the drawers have a soft close function, which means that they close silently.

Designer / Year Of Design

Simon Legald / 2013

Material

Lacquered ash / MDF / Powder coated aluminum

Construction

Kabino comes flat-packed and is assembled using the included assembly manual and tools. Kabino is made of painted MDF with an ash frame mounted to its front. Fronts are made of matt lacquered aluminum. Two Kabinos can be stacked on top of each other if the legs are removed. The size of Kabino Sideboard without legs is H: 51 x L: 114 x D: 42 cm. Load capacity of each drawer: approx. 6-8 kg.

Frame



Ash / White

Fronts



White



Grey



Jalousi sideboard

Jalousi

Interpreting the classic roll-front cabinet

Watches, conveyor belts and 50s furniture were among the sources of inspiration for the Jalousi furniture collection. From this cocktail, Simon Legald has created a contemporary collection of storage furniture, interpreting the classic roll-front cabinet. The Jalousi collection, which consists of a sideboard and cabinets in two different sizes, is characterized by its minimalist idiom and a contrasting mix of materials. All of the designs feature practical rolling shutters in inviting shades of color. The combination of materials and the graphic repetition of the shutter's elements make the style young and masculine. Jalousi is a versatile collection that can be used anywhere storage is required.

Collection

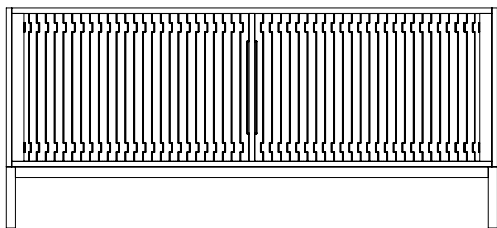

Jalousi sideboard
H: 75 x L: 161 x D: 40 cm

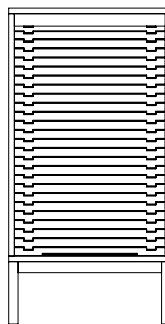

Jalousi cabinet low
H: 101,5 x L: 55 x D: 40 cm

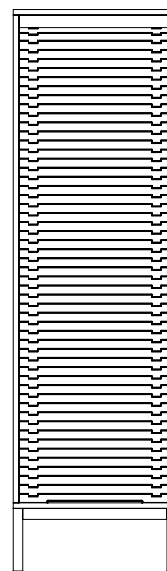

Jalousi cabinet high
H: 180 x L: 55 x D: 40 cm



Jalousi cabinet high



Jalousi cabinet high

Product facts and options

Description

The Jalousi series, which consists of a sideboard and cabinets in two different sizes, is characterized by its minimalist idiom and a contrasting mix of materials. All of the designs feature practical rolling shutters in inviting shades of color, which form an attractive contrast to the cabinet body in an oak veneer with legs of solid oak.

Design

Simon Legald, 2016

Material

MDF, Lacquered oak veneer, ABS

Construction

Jalousi is constructed of MDF and lacquered oak veneer. The front doors are made of ABS.

Colors

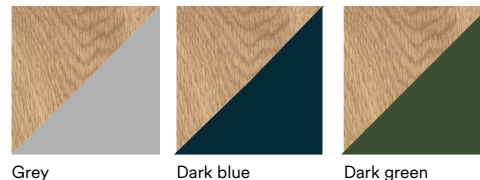

Grey

Dark blue

Dark green

Jet shelf small



Jet

Spacious design in a clear-cut industrial silhouette

The Jet shelf is the result of a designer's play with surfaces and production. The light aluminum shelf has a spacious design and a clear-cut industrial silhouette, making it appear like a part of a jet fighter's aerodynamic construction. The designer, Simon Legald, has experimented with compositions of surfaces, spaciousness and texture and created Jet - a simple yet unconventional wall shelf. An asymmetric relationship between a horizontal and vertical surface creates the Jet shelf's architectural design and comes together as an attractive platform for storage and display.

Product facts and options

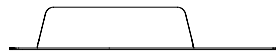

Jet shelf small
H: 11 x L: 80 x D: 21 cm

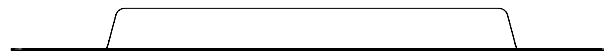

Jet shelf large
H: 11 x L: 160 x D: 21 cm

Description

The light aluminum Jet shelf has a clear-cut industrial silhouette, making it appear like a part of a jet fighter's aerodynamic construction. The profile has small incisions, which create the attractive grooved surface texture. The raw, architectural design forms an attractive platform for storage and display.

Designer / Year Of Design

Simon Legald / 2016

Material

Jet in white and black: Powder coated aluminum

Jet in silver: Aluminum with anodized surface

Construction

Extruded aluminum, CNC cut after extrusion. Delivered with plugs and screws + mounting bracket. The maximum load capacity of the shelves is estimated to 5 kg on Jet shelf small and 10 kg on Jet shelf large.

Colors



White

Black

Silver



Jet shelf small and large

Toj clothes rack small



Toj & Sko

Minimalist construction,
industrial expression

Designer Simon Legald has created a clothes and shoe rack with a clean, industrial expression for Normann Copenhagen. The design's function is evident, and the simple construction provides space for clothes, shoes and bags. Simon Legald has cut to the bone in these minimalist constructions consisting of a frame, hanging rail and shelves. Screws and bolts are accentuated and the shelves' perforated steel casts vivid shadows on the floor.

Product facts and options

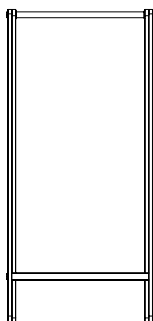

Toj clothes rack small
H: 160 x L: 79,5 x D: 59,5 cm

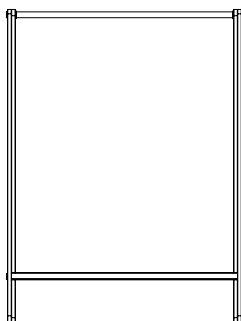

Toj clothes rack large
H: 160 x L: 120 x D: 59,5 cm

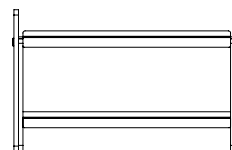

Sko shoe rack
H: 42 x L: 76 x D: 34 cm

Description

Toj clothes rack has an evident function and its simple construction – with a rail, shelf and trusses – provides space for clothes, shoes and bags. Screws and bolts are accentuated and the perforated steel in the shelf's design cast vivid shadows on the floor.

Sko is a shoe rack with a minimal, industrial feel, made from robust materials. Sko has been designed without any unnecessary components. It consists of a wooden frame with two perforated steel shelves held together by accentuated screws.

Design

Simon Legald / 2012

Material

Powder coated steel / Lacquered ash

Construction

Toj clothes rack: Extruded aluminum, CNC cut after extrusion. The screws and bolts are accentuated in the design. Easily assembled by following the included manual. Load capacity: 20 kg on the bar and 30 kg on the shelf.

Sko shoe rack: Including tools for assembly as well an easy-to-follow manual. The large screws keep the frame in position and the shelves are easily put in place. Load capacity: 5 kg per shelf.

Frame

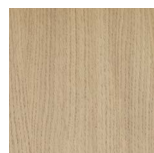

Ash

Shelves



White

Grey



Sko shoe rack

One Step Up bookcase high



One Step Up

An airy and flexible
storage solution

Francis Cayouette's distinctive One Step Up shelving unit is inspired by the form and function of a ladder. Ideal for storage, it can be used alone or as part of a shelving system including several units. One Step Up is flexible and can easily be moved from one place to another. Details, such as the fittings, are accentuated and give the shelving unit authenticity. The natural ash wood and industrial metal shelves create an interesting dynamic.

Product facts and options

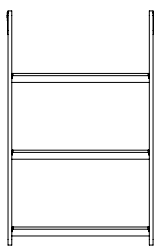

One Step Up bookcase low
H: 126 x L: 78 x D: 45 cm

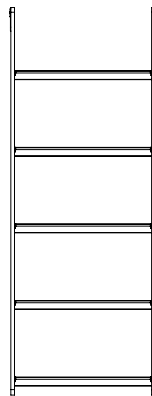

One Step Up bookcase high
H: 200 x L: 78 x D: 45 cm

Description

Inspired by the ladder as an object, designer Francis Cayouette has created One Step Up – a bookcase in a simple functional design. Place various One Step Up bookcases beside each other and create your own bookcase system, or use it as a light room divider.

Design

Francis Cayouette / 2010

Material

Shelves: Powder coated steel
Frame: Lacquered ash

Construction

One Step Up comes flat-packed and is easy to assemble. Just fold out the ladder-like frame and put the shelves in place. Load capacity: approx. 15 kg per shelf.

Frame

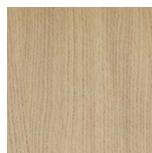

Ash

Shelves

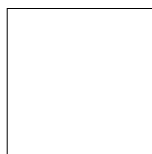

White



Above:
One Step Up bookcase high

Right:
One Step Up bookcase high





Share your experience
@normanncph
#normanncopenhagen

Normann Copenhagen
Niels Hemmingsens Gade 12
1153 Copenhagen, Denmark
Headquarters: +45 35 55 44 59
normann@normann-copenhagen.com
normann-copenhagen.com

